

ATNP/WG3/7 (Munich)

WP/7-14

21/06/96

**AERONAUTICAL TELECOMMUNICATIONS NETWORK PANEL(ATNP)**

**WORKING GROUP 3 - APPLICATIONS AND UPPER LAYERS**

**SUBGROUP 1 - GROUND APPLICATIONS SUBGROUP**

**Draft Guidance Material for the CNS/ATM-1 Package**

**ATS Message Handling Services over the ATN**

**Version 0.2 (Provisional) - Date : 21/06/96**

Prepared by MHS SARPs Editor

**Summary**

This document is the proposed Guidance Material on ATS Message Handling Services (MHS) over the ATN. It complements Version 1.1 of the Draft SARPs for ATS Message Handling Services over the ATN.

WG3 is invited to adopt this material as Version 0.2 of the MHS GM to be presented at ATNP/2, and to provide guidance on the further development of this material towards Version 1.0.

## Document Control Log

<b>Section(s)</b>	<b>Date</b>	<b>New Version</b>	<b>Reason for change</b>
All	09/04/96	0.1 (provisional)	
All	21/06/96	0.2 (provisional)	incorporation of the Brussels SG1 (8th) and WG3 (6th) meeting conclusions

## Table of Contents

<b>CHAPTER 1 - OVERVIEW .....</b>	<b>1</b>
<b>1.1. Introduction</b>	<b>1</b>
1.1.1. Purposes of the SARPs	1
1.1.2. Background	1
1.1.3. Purpose of the document	1
<b>1.2. Application functionalities</b>	<b>2</b>
1.2.1. ATS Message Service Overview	2
1.2.2. ATN Pass-Through Service Overview	2
<b>CHAPTER 2 - ATS MESSAGE SERVICE GUIDANCE.....</b>	<b>1</b>
<b>2.1. System level guidance</b>	<b>1</b>
2.1.1. ATS Message service users	1
2.1.2. AMHS Model	1
2.1.2.1. Functional model	1
2.1.2.1.1. Model components	1
2.1.2.1.2. ATS Message Server overview	2
2.1.2.1.3. ATS Message User Agent overview	3
2.1.2.1.4. AFTN/AMHS Gateway overview	3
2.1.2.1.5. Interaction between AMHS systems	4
2.1.2.2. AMHS information model	5
2.1.2.2.1. Messages	5
2.1.2.2.2. Probes	5
2.1.2.2.3. Reports	5
2.1.2.3. Security model	6
2.1.2.4. Management model	6
2.1.3. AMHS Organization	6
2.1.3.1. AMHS Management Domains	6
2.1.3.2. Relations between AMHS Management Domains	7
2.1.4. AMHS Naming and Addressing	7
2.1.4.1. AMHS Naming	7
2.1.4.1.1. Naming of AMHS users	7
2.1.4.1.2. Upper Layer naming	8
2.1.4.2. AMHS Addressing	8
2.1.4.2.1. Addressing of AMHS users	8
2.1.4.2.2. Upper Layer addressing	9
2.1.4.3. Relationships between these concepts	9
<b>2.2. ATS Message Service Description</b>	<b>10</b>
2.2.1. Specification Scheme	10
2.2.1.1. Introduction to MHS Profiles	10
2.2.1.2. Classification of requirements	11
2.2.1.3. AMHS service characteristics for support of the Basic ATS Message Service	12
2.2.2. ATS Message User Agent Profile Description	13
2.2.2.1. Body part contents	13

2.2.2.2. Use of priority-indicators and notification-requests	15
2.2.3. ATS Message Server Profile Description	15
2.2.3.1. Upper layer profile	15
2.2.3.2. Use of the Transport Service	16
2.2.3.2.1. Use of the ATN Transport Service	16
2.2.3.2.2. Use of the Transport Service for the AMH112 Profile	16
2.2.3.2. Logging functions at an ATS Message Server	16
<b>2.3. AFTN/AMHS Gateway Description</b>	<b>17</b>
2.3.1. General presentation	17
2.3.2. Functional decomposition	17
2.3.2.1. AFTN Component	18
2.3.2.2. ATN Component	18
2.3.2.3. Message Transfer and Control Unit	18
2.3.2.4. Other components	19
2.3.2.5. Interface between the ATN Component and the Message Transfer and Control Unit	19
2.3.2.6. Interface between the AFTN Component and the Message Transfer and Control Unit	20
2.3.3. Traffic Logging in an AFTN/AMHS Gateway	20
2.3.3.1. AFTN Component traffic logging	20
2.3.3.2. ATN Component traffic logging	20
2.3.3.3. Message Transfer and Control Unit traffic logging	21
2.3.3.4. Relationship between these traffic logs	21
2.3.4. Address conversion in an AFTN/AMHS Gateway	21
2.3.5. Conversion functions of an AFTN/AMHS Gateway	21
2.3.5.1. AFTN to AMHS Conversion	22
2.3.5.1.1. Converted information objects	22
2.3.5.1.2. Guidance on error situations	23
2.3.5.2. AMHS to AFTN Conversion	23
2.3.5.2.1. Converted Information objects	23
2.3.5.2.2. Behaviour upon receipt of non-delivery reports	24
2.3.5.2.3. Guidance on error situations	24
<b>3. ATN PASS-THROUGH SERVICE GUIDANCE .....</b>	<b>1</b>
<b>APPENDIX A : DEFECT REPORT ON GROUND-GROUND APPLICATION SARPS.....</b>	<b>1</b>

## **CHAPTER 1 - OVERVIEW**

### **1.1. INTRODUCTION**

#### **1.1.1. Purposes of the SARPs**

to be detailed

#### **1.1.2. Background**

to be detailed

#### **1.1.3. Purpose of the document**

to be detailed

## **1.2. APPLICATION FUNCTIONALITIES**

### **1.2.1. ATS Message Service Overview**

Two levels of service are defined within the ATS Message Service:

- a) the Basic ATS Message Service.
- b) the Extended ATS Message Service.

The Basic ATS Message Service meets the basic requirements of the MHS Profiles published by ISO as International Standardized Profiles (ISPs), and it incorporates additional features to support the service offered by the AFTN. The Basic ATS Message Service is further specified in section 2.2.1.3. This includes the specification of which ISPs apply in this context.

The Extended ATS Message Service will provide functionalities in addition to those of the Basic ATS Message Service which are either one or several of the following:

- a) functionalities which are optional in the ISPs which apply in the context of the Basic ATS Message Service.
- b) functionalities included in ISPs which do not apply in the context of the Basic ATS Message Service.
- c) functionalities included in future editions of the ISO/IEC and ITU-T MHS Standards and Recommendations.

An example of a) could be that the Extended ATS Message Service mandates the use of a Functional Group (e.g. Use of Directory) which is optional in the Basic ATS Message Service. An example of b) could be that the Extended ATS Message Service is based on a different category of service (e.g. EDIMS) defined in the MHS profiles. An example of c) could be the "business-class user extensions" currently under discussion at ISO and ITU-T, which define standard extensions to the IPM Heading fields, among which some could potentially be used for the conveyance of items such as the filing time and the optional heading information currently carried in the ATS-Message-Header (i.e. in the body) of an AMHS IPM.

The detailed specification of the Extended ATS Message Service is not included in the CNS/ATM-1 Package SARPs. It is for further study and inclusion in future packages.

The term ATS Message Service refers to the service which includes both the Basic and the Extended ATS Message Service where no distinction between these is necessary.

The ATS Message Service is the long-term solution amongst the ATS Message Handling Services defined over the ATN. This means that in the long-term, the ATS Message Service is aimed at becoming the single generic messaging service over the ATN.

### **1.2.2. ATN Pass-Through Service Overview**

to be detailed

---

## CHAPTER 2 - ATS MESSAGE SERVICE GUIDANCE

### 2.1. SYSTEM LEVEL GUIDANCE

#### 2.1.1. ATS Message service users

Two categories of users of the ATS Message Service are defined in the SARPs:

- a) direct users;
- b) indirect users.

Direct users are those who make use of an ATS Message User Agent to access the ATS Message Service. The use of a UA gives them a potential access to:

- a) the MHS Elements of Service supported in the Basic ATS Message Service (see 2.2.1.3),
- b) optional MHS Elements of Service in addition to those which are mandatory in the Basic ATS Message Service.

Direct users may belong to two subgroups as follows:

- a) human users who interact with the ATS Message Service by means of a man-machine interface with an ATS Message User Agent connected to an ATS Message Server; and
- b) host users which are computer applications running on ATN end systems and interacting with the ATS Message Service by means of application programme interfaces. Such APIs are out of the scope of the SARPs.

Indirect users are those users located at an AFTN station which can only reach the AMHS via an AFTN/AMHS Gateway. Such users therefore have access only to the AMHS functionalities which have a direct equivalent in the AFTN.

#### 2.1.2. AMHS Model

##### 2.1.2.1. Functional model

###### 2.1.2.1.1. Model components

The set of ATS Message Servers, ATS Message User Agents and AFTN/AMHS gateways is known collectively as the ATS message handling system (AMHS). The set of protocols implemented between these systems is called the ATS Message Protocol Stack Type B.

Since the AMHS operates in a store-and-forward mode, the number of ATN end systems involved in an end-to-end message transfer in the AMHS depends on each message being transferred, i.e. on its originator and recipient, as well as on the routing adopted for that message by the involved ATS Message Servers, at the moment of its conveyance.

In the case of a single message end-to-end conveyance in the AMHS, a number of ATS Message Servers and two systems among ATS Message UAs and AFTN/AMHS gateways are involved. Following the concepts of the MHS Standards, it is necessary here to distinguish between the following components, or "building bricks", of the ATS Message Servers, and of the AFTN/AMHS gateways which all handle the ATS Message Protocol Stack Type B:

- a) **message transfer agent (MTA)** which handles the "P1 protocol" (MTS transfer protocol) for the message exchange between a pair of MTAs. A set of interconnected MTAs forms a "message transfer system" (MTS).
- b) **user agent (UA)** which is the interface between the user of the AMHS and the MTS. For the support of the Basic ATS Message Service, UAs provide the "interpersonal messaging (IPM) service", exchanging messages across the MTS from UA to UA by means of the "P2 protocol" (interpersonal messaging protocol).
- c) **message store (MS)** which provides the MTA with a storage capability and which offers services allowing the UA to retrieve messages stored in the MS at its convenience. There are usually several UAs or MSs served by one MTA.
- d) **access unit (AU)** which in the AFTN/AMHS gateway provides the conversion capability supporting the interworking between the AFTN and the UAs of the AMHS. In the general MHS environment, AUs define how UA users can communicate with users of non-MHS technologies (e.g. telex). However, for the AMHS no use of such standardized AU types is made.

#### 2.1.2.1.2. *ATS Message Server overview*

An **ATS Message Server** comprises a MTA and optionally one or several MSs. As far as upper layer MTA-to-MTA communications are concerned, i.e. above the transport layer, the SARPs only require compliance with the AMH22 Profile and support of the IPM Distribution List Functional Group. This means that at this level, there is no "ATN-specific" requirement in the ATS Message Server specification. The interface between the ATS Message Server and the UAs it serves, either directly or through an MS, has been left open in the SARPs since this is often an implementation matter local to each Management Domain (see section 2.1.2.1.3 for more details).

If the ATS Message Server comprises any optional MS, then such a MS is an IPM-MS. At the level of the IPM-MS the "ATN-specific" structured body is internal to the IPM body, and therefore it has no implication on the MS.

Figure 2.1 gives a simplified functional view of the ATS Message Server.

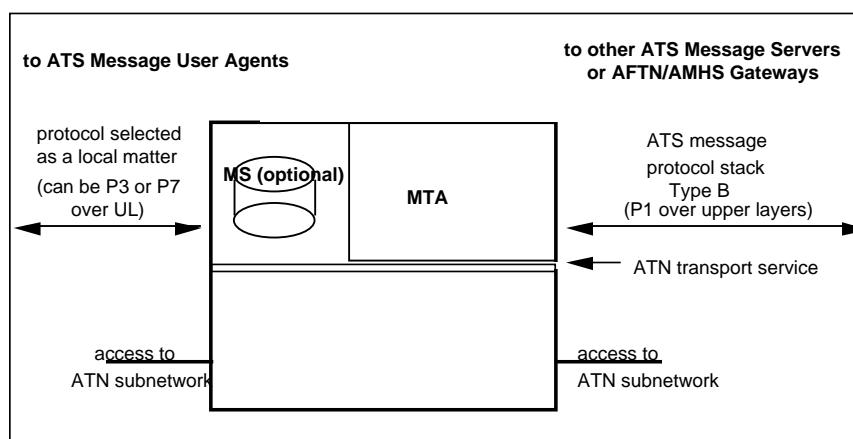

**Figure 2.1: Functional view of the ATS Message Server**



#### **2.1.2.1.3.      *ATS Message User Agent overview***

An **ATS Message User Agent** comprises a UA. In the Basic ATS Message Service, this UA is an IPM-UA which supports additional "ATN-specific" features in order to comply with the mandatory requirement of AFTN interworking. These additional requirements are related to the structure of the IPM body, they are detailed in 2.2.2.1.

As mentioned above, the interface between the ATS Message UA and the ATS Message Server at the level of upper layer UA-to-MTA communications (and vice-versa) are concerned, i.e. above the transport layer, is a local implementation matter. The options at this level are as follows:

- a) use the P3 protocol, if no MS is implemented in the ATS Message Server. In such a case, the use of the AMH23 Profile as specified in ISO/IEC ISP 12062-4 is the preferred implementation choice;
- b) use the P7 protocol, if MSs are implemented in the ATS Message Server. In such a case, the use of the AMH24 Profile as specified in ISO/IEC ISP 12062-5 is the preferred implementation choice; and
- c) use a locally-defined protocol, in the case of logically co-located UAs.

An ATS Message User Agent is by definition an ATN End System. The existence of this definition does not preclude the implementation, as a local matter, of UAs supporting a service identical to the Basic ATS Message Service without making use of the ATN for the interconnection between the UA and an ATS Message Server. Such UAs are also considered as logically co-located. In all cases logically co-located UAs in the AMHS are IPM-UAs supporting the structured IPM body defined in 2.2.2.1.

#### **2.1.2.1.4.      *AFTN/AMHS Gateway overview***

An AFTN/AMHS Gateway implements a MTA, and an AU. As further described in 2.3, the MTA forms the ATN Component of the AFTN/AMHS Gateway, and the AU is the Message Transfer and Control Unit of the AFTN/AMHS Gateway.

An AFTN/AMHS Gateway also implements an AFTN Component, however in strict terms this component does not pertain to the AMHS.

Figure 2.2 gives a functional view of the AFTN/AMHS Gateway.

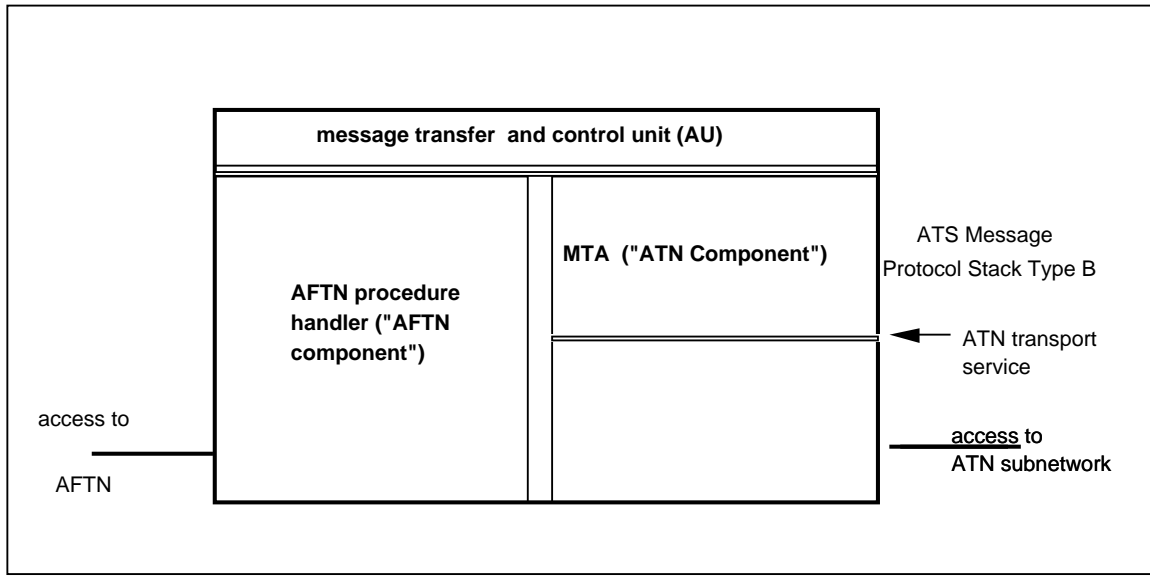

Figure 2.2: Functional view of the AFTN/AMHS Gateway

2.1.2.1.5. Interaction between AMHS systems

Figure 2.3 illustrates different potential relationships together with examples of message flows between the systems which are part of the AMHS.

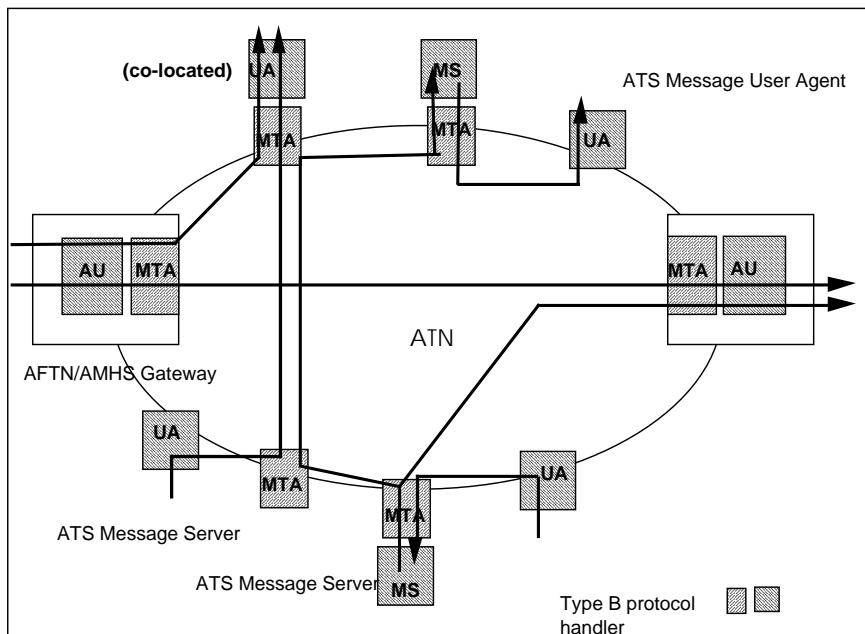

Figure 2.3: Examples of AMHS message flows

Other configurations are also possible, for example an MTA+AU+MS/UA may also be obtained by co-location of an AFTN/AMHS Gateway and one or several UAs.

Figure 2.3 illustrates that functions such as routing ("relaying") and multiple dissemination of messages to different recipients are performed by the MTAs included either in an ATS Message Server or in an AFTN/AMHS Gateway.

#### **2.1.2.2. AMHS information model**

In conformance with ISO/IEC 10021-2 three categories of information objects are conveyed in the AMHS: message, probe and report.

##### **2.1.2.2.1. Messages**

Messages are composed of two parts, the envelope and the content.

An envelope is generated by an ATS Message User Agent or an AFTN/AMHS Gateway when entering the AMHS. The envelope bears all the information necessary for the conveyance of the message by the ATS Message Servers towards its destination. The information carried by the envelope varies along the conveyance of the message towards its destination.

The type of envelope which is used for the submission/delivery of a message between an ATS Message User Agent and an ATS Message Server is related to the protocol implemented between the two systems. Therefore it is out of the scope of the SARPs (see 2.1.2.1.3).

In consequence, the specifications included in the SARPs deal only with Transfer Envelopes, used from MTA to MTA, i.e. either between two ATS Message Servers, between two AFTN/AMHS Gateways or between an ATS Message Server and an AFTN/AMHS Gateway.

The content of the message is an information object which the MTAs neither examines nor modifies, except for conversion, during its conveyance of the message. Messages generated in the Basic ATS Message Service are always Inter-Personal Messages (IPM). Two types of content conversion may be performed in the AMHS:

- a) conversion of the content encoded-information-types, as specified in the base standards. Such a conversion is optional in the AMHS since there is no clause mandating the support of the Conversion Optional Functional Group as specified in the ISPs. It may be implemented in the MTAs, as a local matter; and
- b) message content conversion in an AFTN/AMHS Gateway for a message conveyed from the AMHS to the AFTN. Such a conversion capability is necessary for interworking between the two messaging environments. It is further detailed in the AFTN/AMHS Gateway specification (see 2.3.5).

##### **2.1.2.2.2. Probes**

A probe is a class of message containing only an envelope which is conveyed by the MTAs from one user up to the MTA serving other users. It may be used to determine the deliverability of messages.

In the AMHS, probes are generated, if supported, at an ATS Message User Agent. An AFTN/AMHS Gateway does not generate probes.

##### **2.1.2.2.3. Reports**

A report is an information object generated by a MTA in order to report on the outcome or progress of a message or probe in the set of interconnected MTAs pertaining to the AMHS.

In the AMHS, reports are generated by an ATS Message Server or by an AFTN/AMHS Gateway. Within an AFTN/AMHS Gateway, the report may be generated either by the MTA comprised in the ATN Component (as usual for any MTA), or by the Access Unit (see 2.3.2.5).

#### **2.1.2.3. Security model**

The MHS standards include Elements of Service related to security. However, in the CNS/ATM-1 Package, i.e. for the support of the Basic ATS Message Service, their implementation is optional. It is expected that these EoS will be used in future Packages to ensure the AMHS security.

Therefore, in the Basic ATS Message Service, security is deemed a local issue, to be addressed as appropriate at each ATN End System pertaining to the AMHS by the authority in charge of the system. It may be noted that also in the base standards, certain Security EoSs such as the Access Management between UA and MTA is specified as "local matter".

#### **2.1.2.4. Management model**

In the Basic ATS Message Service, management is limited to the logging provisions which are defined with two main goals:

- a) ensuring message traceability, i.e. with the objective of keep track of the information objects which passed in, through and out of an ATN End System pertaining to the AMHS, and of the action taken thereon;
- b) maintaining a long-term traffic log of the entire traffic upon origination, for safety and administrative purposes, e.g. in case an investigation would be necessary.

In the AFTN, this function is called long-term retention, and the retention duration is specified as being 30 days. There is no duration specified in the SARPs, however the SARPs provisions are intended to offer the same level of functionality (traceability and originated traffic recording) as currently provided in the AFTN.

Within a given AMHS Management Domain, the place where the originated traffic is recorded is a local matter. This may be done e.g. at the originating ATS Message Server, at the originating ATS Message User Agent, or at a specifically dedicated system by ad-hoc means. At an AFTN/AMHS Gateway, there is no need to record all the generated AMHS traffic since a message generated at an AFTN/AMHS Gateway as the result of the conversion of an AFTN message has already been logged in the AFTN for long-term retention.

For any piece of information, for which a logging requirement is present in the SARPs, the way in which the information specified is logged is an implementation matter, which is out of the scope of the SARPs. Also the way in which the information specified is retrieved, exchanged and used is an implementation matter, which is out of the scope of the SARPs.

### **2.1.3. AMHS Organization**

#### **2.1.3.1. AMHS Management Domains**

For purposes of organization, addressing, routing etc. it is necessary to define an organizational structure for the AMHS.

MHS Standards require the organization of an MHS into domains which govern its management.

The organizational structure of the AMHS is aligned on these concepts without further refinement. This means that organizationally, the AMHS is made of AMHS Management Domains each of them compliant with the definition of a MHS Management Domain as may be found in the base standards.

Flexibility is given to the organizations participating in the AMHS, by the possible choice for an AMHS Management Domain to operate either as an ADMD or as a PRMD.

Each AMHS Management Domain is responsible, among other things, for:

- a) carrying out the relevant administrative procedures such as MD-registration;
- b) managing the equipment required to provide the ATS Message Service in its area of responsibility, among which at least one MTA, included either in an ATS Message Server or in an AFTN/AMHS Gateway;
- c) managing the O/R Names and O/R Addresses (MF-Addresses) of all its service-users, allowing these users to be uniquely identified in the AMHS;
- d) managing the routing internal to the Management Domain and the multilateral agreements related to inter-Management Domain routing; and
- e) defining the various policies specified as a matter of local policy in the SARPs.

#### **2.1.3.2. Relations between AMHS Management Domains**

Each AMHS Management Domain must be interconnected over the ATN with at least one other AMHS Management Domain, which is then called "adjacent". The concept of adjacent domains is not related to geographical considerations, but to a direct telecommunications relationship over the ATN between resources belonging to these organizations.

The communication between two AMHS Management Domains is always MTA to MTA, i.e. either:

- a) from ATS Message Server to ATS Message Server;
- b) from ATS Message Server to AFTN/AMHS Gateway; or
- c) from AFTN/AMHS Gateway to AFTN/AMHS Gateway.

This means that the protocol implemented between two AMHS Management Domains is P1. For messages generated in the Basic ATS Message Service, these messages are IPMs including the structured body defined for the AMHS. However at the level of Message Transfer this is not considered by the AMHS systems (ATS Message Server or AFTN/AMHS Gateway) involved in the "point-to-point" communication between the two AMHS Management Domains.

#### **2.1.4. AMHS Naming and Addressing**

##### **2.1.4.1. AMHS Naming**

AMHS naming encompasses two different aspects:

- a) naming of AMHS users, which is made by means of O/R names,
- b) naming of the application processes and application entities in the ATN End Systems participating in the AMHS.

##### **2.1.4.1.1. Naming of AMHS users**

An O/R name identifies uniquely in the global MHS the name of a particular user. This name may take two forms, which are either the form of a Directory Name or the form of an O/R Address.

In the AMHS as defined in the CNS/ATM-1 Package SARPs, since the Use of Directory is optional in the Basic ATS Message Service, O/R names of AMHS users can only take the form of an O/R Address, which is denominated a MF-address in the AMHS (see 2.1.4.2.1).

#### **2.1.4.1.2. Upper Layer naming**

Each application entity participating in the AMHS may be identified with a unique name which is an Application Entity Title. An Application Entity Title comprises an Application Process Title and an Application Entity Qualifier.

This AET may be used at the establishment of the association between two communicating MHS applications. It is an optional parameter of the A-Associate service primitive of ACSE, for both the calling entity and the called entity.

#### ***to be completed in line with the SARPs***

#### **2.1.4.2. AMHS Addressing**

Like naming, AMHS addressing encompasses two different aspects:

- a) addressing of AMHS users, which is used for message routing from an AMHS user and delivery to another AMHS user, among the MTAs pertaining to the AMHS. This is made by means of O/R addresses; and
- b) addressing of the upper layer entities in the ATN End Systems participating in the AMHS.

#### **2.1.4.2.1. Addressing of AMHS users**

Two address forms are defined to identify users in the AMHS, which are as follows:

- a) an AF-Address is used to locate AMHS users, either direct or indirect, in the AFTN address space;
- b) a MF-Address is used to locate a direct or indirect AMHS user in the AMHS address space.

An AF-Address (AFTN-form) is an ICAO AFTN 8-letter addressee indicator.

A MF-Address (MHS-form) is a MHS O/R address without particular restrictions or specifications other than those relative to the AMHS Management Domain which the user belongs to.

By definition, an indirect user has an AF-Address. If a direct user needs to communicate with indirect users, it is required that an AF-Address be allocated to him. The way in which this AFTN address is allocated is an administrative matter outside the scope of the SARPs.

The selection of the AMHS Addressing Scheme is usually a matter of policy local to each AMHS Management Domain. This addressing scheme may be either a local one or a Common AMHS Addressing Scheme, or a combination of these. Common AMHS Addressing Schemes are common schemes established at the level of ICAO. The adoption of a scheme, or the decision that every AMHS Management Domain within ICAO should use one or another Common AMHS Addressing Scheme is an institutional matter, which is therefore out of the scope of SARPs.

One single Common AMHS Addressing Scheme is defined in the CNS/ATM-1 Package SARPs. It is called the XF-Addressing Scheme and it is the preferred addressing scheme for indirect users, unless, for any particular reason, a more user-friendly O/R address is desired.

An XF-Address comprises exclusively the following attributes:

- a) C = either of the following:
  - 1) two-character alphabetical country-indicator as specified in ISO 3166;
  - 2) three-digits data-country-code as specified in CCITT recommendation X.121; or
  - 3) the two-letter alphabetical value reserved for international registration;
- b) A = admd-name or single-space
- c) P = prmd-name (present only if the AMHS Management Domain operates as a PRMD)
- d) O = "AFTN"
- e) OUI = 8-letter addressee indicator (AF-address of the user).

#### **2.1.4.2.2. Upper Layer addressing**

Upper layer addresses include:

- a) the TSAP address which identifies the Transport Service-user, i.e. the session entity in an AMHS system. It comprises the NSAP address of the ATN End System complemented with a T-Selector;
- b) the SSAP address which identifies the Session Service-user, i.e. the presentation entity in an AMHS system. It comprises the TSAP address complemented with a S-Selector;
- c) the PSAP address which identifies the Presentation Service-user, i.e. the presentation entity in an AMHS system. It comprises the SSAP address complemented with a P-Selector.

The allocation of the NSAP address obeys to the rules defined in Sub-Volume 5. The allocation of T-, S- and P-selectors is considered as a local matter for the organisation responsible for an AMHS system, and consequently for each AMHS Management Domain.

#### **2.1.4.3. Relationships between these concepts**

AMHS systems are by essence ground fixed systems. Therefore the mapping of an AET onto a PSAP address is unambiguous and static, unless in case of reconfiguration.

When trying to route an AMHS message (or probe, or report) in an ATS Message Server, the routing tables of the MTA are analysed to determine either of the following, based on the MF-Address of the message recipient:

- a) the upper layer address of the recipient's UA, if the ATS Message Server is the delivering MTA, i.e. the last MTA in the sequence of MTAs in the end-to-end communication from UA (or Gateway) to UA (or Gateway); or
- b) the upper-layer address of the next hop MTA if the recipient is not local to the current ATS Message Server.

In the first case, the UA's upper layer address which is found in the routing tables depends on the type of protocol implemented between the UA and the ATS Message Server, which is a local matter in the AMHS.

In the latter case, the mapping, which is performed using the static MTA routing tables, usually derives a mta-name from the recipient O/R address, and the PSAP address corresponding to the mta-name. The AET of the next hop MTA, if configured, may also be found in the table. These parameters are used to establish an association, or use an existing one, with the determined next hop MTA.

When submitting an AMHS message (or probe) at an ATS Message User Agent, the situation is different since a UA usually communicates with one single MTA, which is always the same unless in case of reconfiguration. Therefore no mapping nor routing is required, since static parameters are simply configured and used in the considered UA.

## 2.2. ATS MESSAGE SERVICE DESCRIPTION

### 2.2.1. Specification Scheme

#### 2.2.1.1. Introduction to MHS Profiles

The specifications on which the AMHS is based are very extensive and contain many functions which do not need to be implemented in the AMHS. For this reason, it is necessary to specify a “profile” which describes the functions to be included. Such profiles which have been standardized by ISO are known as ISPs (international standardized profiles).

Profiles standardize the use of options and other variations in the base standards, and provide a basis for the development of uniform, internationally recognized system tests.

Implementations may then claim conformance with the ISPs, which in this way promote system interoperability without the users having to specify their own combination of functions among those made available by the base standards.

ISPs are classified in ISO/IEC TR 10000:1992, which is the Framework and Taxonomy of International Standardized Profiles. In this document, the ISO MOTIS is arranged under Application Profiles: Message Handling (AMH). For Common Messaging, i.e. for the Message Transfer System (MTS), for the MTS-Access and for the MS-Access the profiles AMH1n (n=1 to 3) are relevant; for the Interpersonal Messaging Service (IPMS) the profiles AMH2n (n=1 to 4) are relevant, while for the Electronic Data Interchange Messaging Service (EDIMG Service) the profiles AMH3n (n=1 to 4) are relevant. Figure 2.4 depicts, for each of the AMH set of profiles, where each AMHnn applies.

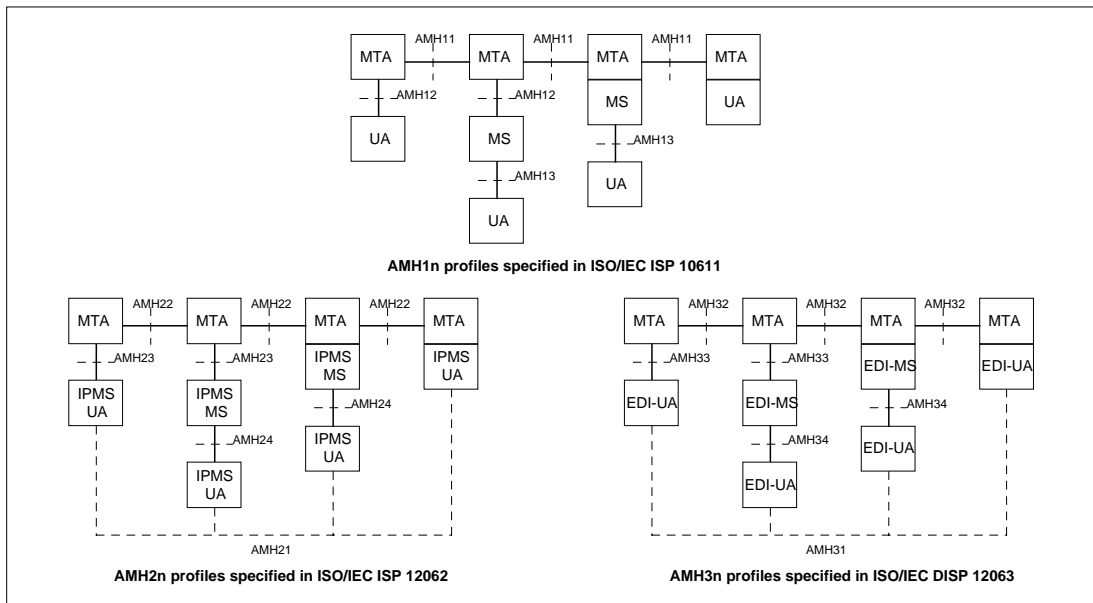

Figure 2.4: Applicability of AMH Profiles

Additionally, each of the ISPs includes a first part to describe the overall specifications of the support of the Elements of Service (EoS) and associated functionalities which are not appropriate for consideration only from the perspective of a single MHS protocol.



In the context of the Basic ATS Message Service, the AMH2n set of Profiles are those which are applicable.

**2.2.1.2. Classification of requirements**

The specification scheme is based on sets of Elements of Service (EoS). An EoS is a well-defined MHS function provided by a MHS functional object such as MTA, UA, MS or AU or by the MTS (i.e. the set of interconnected MTAs) and is defined in ISO/IEC 10021. An element of service usually leads to the inclusion of specific fields in the protocol data units.

The AMHS profiles makes reference to Part 1 of the ISPs for the general specification of the supported EoS, and also to the relevant AMH profiles for the protocols supported by the AMHS.

The ISPs define the terms "basic requirement" and "functional group". The "basic requirements" are Elements of Service and associated features (e.g. protocol elements) which are required to be supported by all MHS implementations. A "functional group" is a set of one or several EoS which are related to each other, and the associated features, which together support a significant optional area of MHS functionality.

An EoS which is part of a functional group may be optionally supported by an implementation claiming only conformance to the basic requirements. On the other hand, an implementation claiming conformance for support of the optional functional group means that it is supported as a whole, i.e. all EoS and associated features part of the functional group are implemented.

In some cases, the partial support of an EoS may be included in the basic requirements, while its "full support" is part of an optional functional group. This may happen for example, to allow the proper end-to-end "transport" of a functionality across the MTS when this optional functionality is implemented.

The basic requirements together with the complete set of optional functional groups, as specified in ISO/IEC ISP 10611 (Common Messaging), make up the complete set of MHS functions related to common messaging, i.e. non content-dependent specific functionalities. This is illustrated in Figure 2.5.

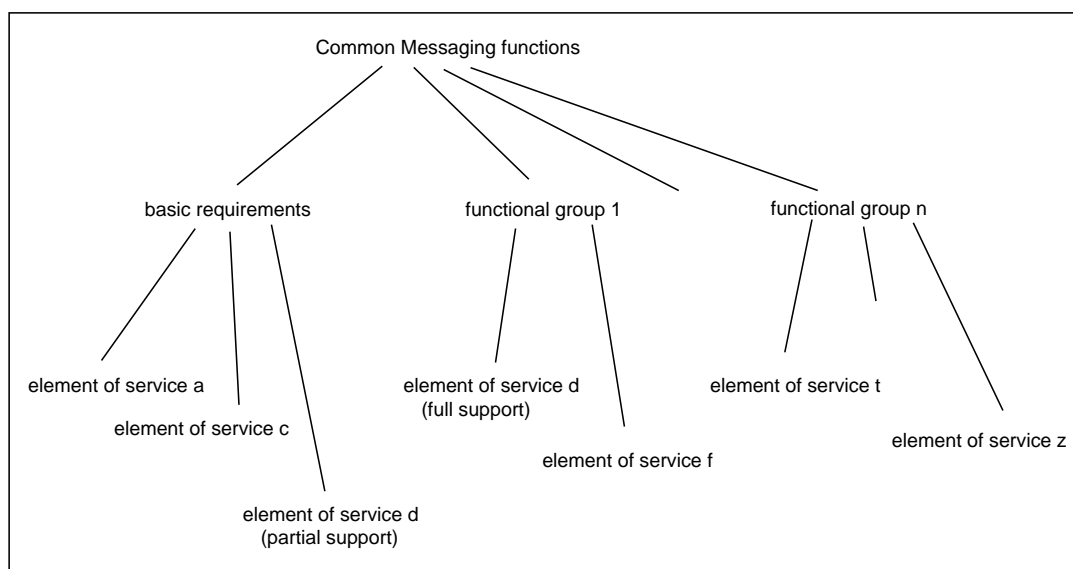

**Figure 2.5. Relationship of elements of service and functional groups.**

The elements of service of the optional functional groups may be implemented, but by definition they do not have to be implemented. If they are implemented, then the implementation must conform to the base definitions in ISO/IEC 10021 and to the clauses of ISO/IEC ISP 10611 and the EoS must be treated as if it were specified as mandatory support. If they are not implemented, then the functions corresponding to the elements of service are simply not carried out. However the absence of the functions may not cause a protocol error to be generated when a protocol data unit referring to a non-implemented element of service is received. This requirement allows a basic compatibility among all ATS Message Servers even when these have different levels of functionality, for example between the ATS Message Servers which implement the Basic ATS Message Service and those which, in the future, will implement the Extended ATS Message Service. Such optional functional groups could, for example, be usefully employed within an area administered by one authority (AMHS Management Domain) or between pairs of AMHS Management Domains based on bilateral agreements.

It is expected that in the future, i.e. in the Extended ATS Message Service, the Security (SECn) and Use of Directory (DIR) Functional Groups could be used, since they would bring useful functionality to ensure the AMHS security and to ease the management of O/R names.

### **2.2.1.3. AMHS service characteristics for support of the Basic ATS Message Service**

As already introduced in section 2.1.2.1, the AMHS includes a set of UAs, AUs together with the MTS. When supporting the Basic ATS Message Service, the service performed by UAs and AUs is the Interpersonal Messaging Service (IPM Service) as defined in the MHS Standards.

The AMH21 Profile, as specified in ISO/IEC ISP 12062-2: 1994, applies on an end-to-end basis between the UAs and, by extension, the AUs belonging to the AMHS, which are implemented in the ATS Message User Agents and AFTN/AMHS Gateways, and which support the Basic ATS Message Service.

The IPM Service characteristics, as supported by the AMH21 Profile for the requirements of the AMHS in the context of the Basic ATS Message Service, are described in the context of the ATS Message User Agent in section 2.2.2. This description also includes the additional requirements necessary for interworking with the AFTN.

The AMH22 Profile, as specified in ISO/IEC ISP 12062-3: 1994, applies between ATS Message Servers, between an ATS Message Server and an AFTN/AMHS Gateway, and between two AFTN/AMHS Gateways. It may be noted that this implies that the AMH11 Profile, as specified in ISO/IEC ISP 10611-3, is also applicable between the ATS Message Servers and AFTN/AMHS Gateways.

The MT Service characteristics, as supported by the AMH22 Profile for the requirements of the AMHS in the context of the Basic ATS Message Service, are described in the context of the ATS Message Server in section 2.2.3.

The use of the AMH Profiles as presented above is illustrated in Figure 2.6.

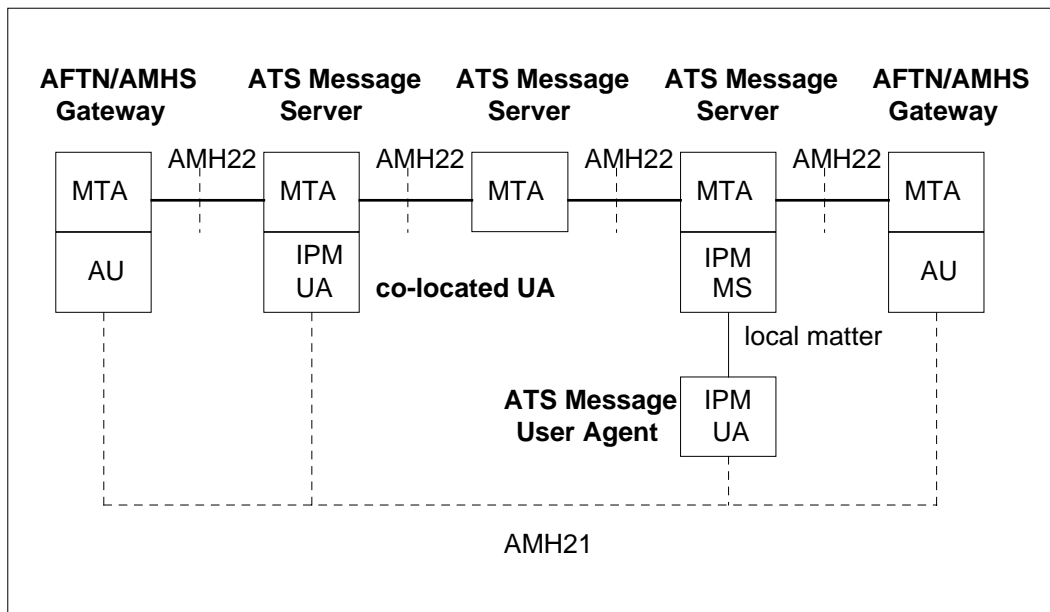

Figure 2.6 : Use of AMH Profiles in the AMHS

**2.2.2. ATS Message User Agent Profile Description**

The AMHS Profile for an ATS Message User Agent includes only the specification of the Message Content, i.e. the support of AMH21 as introduced in 2.2.1.3, and additional requirements related to the interworking with the AFTN.

These additional requirements are related to:

- a) the contents of the ia5-text or general-text body part; and
- b) the support of receipt-notification-requests which is mandatory in origination, while it is optional in AMH21.

**2.2.2.1. Body part contents**

As mentioned in 2.1.2.1.3, an ATS Message User Agent uses a structured body part to convey message components which are necessary for AFTN interworking.

This structured body part comprises:

- a) an aTS-Message-Header element, which conveys the AFTN parameters which have no direct equivalent in MHS standards,
- b) an aTS-Message-Text element, which conveys the text of the message itself.

The parameters conveyed by means of the aTS-Message-Header are the following:

- a) priority indicator, which is conveyed in a structure called aTS-Message-Priority,
- b) filing time, which is conveyed in a structure called aTS-Message-Filing-Time, and

- c) optional-heading-information, which is conveyed in a structure called aTS-Message-Optional-Heading-Info.

For conformance with the SARPs, an ATS Message User Agent must include the static capability to support these parameters. This means that the ATS Message User Agent must be able to generate the mandatory elements, which are the aTS-Message-Priority and the aTS-Message-Filing-Time, and may be able to optionally generate the aTS-Message-Optional-Heading-Info. Like for most of the IPM Heading Fields, the ATS Message User Agent is not mandated to generate these parameters for each submitted message, but only to have the capability to generate them. However, the aTS-Message-Priority and the aTS-Message-Filing-Time parameters are mandatory for messages directed to the AFTN, and their absence in a message will cause rejection at an AFTN/AMHS Gateway.

The aTS-Message-Header is composed of uppercase IA5IRV characters, including prompts to allow a reader to identify easily the included parameters. When displayed using a man-machine-interface which does not interpret the aTS-Message-Header, the external appearance of an AMHS Message would be as in the following example:

```
PRI: FF
FT: 281120
OHI: DEFG2345... (if present)
(blank line)
(Beginning of message text)
```

Furthermore the aTS-Message-Header starts with a non-printable character which is SOH (which may be typed in, if required, using the Alt-1 keys in an MS-DOS or Windows environment) and ends with another non-printable character which is STX (which may be typed in, if required, using the Alt-2 keys in an MS-DOS or Windows environment).

This structured header may be generated by different means, such as:

- a) it may be directly typed in within the body part, by a direct user at an off-the-shelf UA. This allows to use standard off-the-shelf UAs with their default man-machine interface without particular additions for the AMHS;
- b) it may be generated by an additional input/display grid placed in the man-machine interface of the UA. In such a case the user would for example only type in the value of the priority-indicator and of the filing-time. Syntactic checks on these values may also be incorporated in the add-on in this case;
- c) other approaches are possible, e.g. to generate automatically the filing time, etc.

The reasons for the conveyance of these parameters are the following:

- a) there is a need for complete transparency for messages conveyed in the AFTN, then converted to the AMHS, and then converted back to the AFTN;
- b) the AFTN priority indicator has five possible values, which bear different semantic meanings, and which are therefore not strictly equivalent to the three MHS priority levels, although in the AFTN there are only three transmission priority levels;
- c) in the Aeronautical Fixed Service (AFS), the filing time bears a semantic value which may be different from that of the MHS submission-time;
- d) for interworking purposes, there is a need to convey towards the AMHS message recipient the optional heading information, if present, which was carried in the AFTN Heading of a message converted from the AFTN to the AMHS.

### 2.2.2.2. Use of priority-indicators and notification-requests

In the AMHS, the MHS priority value "urgent" is reserved for distress messages, i.e. messages with the highest priority level, which priority indicator is "SS" in the AFTN and the aTS-Message-Priority element.

Furthermore, notification requests are used exclusively for messages with this highest priority level, in line with the principles adopted in the AFTN, where positive message acknowledgements only exist for SS messages. In such a case the notification-request parameter takes the value "rn". For this purpose, an ATS Message User Agent must be able to generate such a notification request, although this is only optional in AMH21.

This means that three parameters are correlated in an AMHS message, and may be used only in conjunction with one another. They are the following:

- a) the MHS *priority* element of the Message Transfer Envelope,
- b) the priority-indicator in the aTS-Message-Header, and
- c) the *notification-requests* in the *primary-recipients*, *copy-recipients* and *blind-copy-recipients* fields of the IPM Heading.

The correlation between these parameters may be done either automatically, using the add-on functionality implemented at the man-machine interface of an UA, or manually, with the potentiality of generating errors if the consistency is not properly ensured by the human end-user.

### 2.2.3. ATS Message Server Profile Description

#### 2.2.3.1. Upper layer profile

The AMHS Profile for an ATS Message Server includes only the specification of the AMH profile as specified in ISO/IEC ISP 12062, which in turn implies several conformance requirements, in accordance with the principles described in 2.2.1.

The applicable profile is AMH22, which implies conformance with AMH111. The only additional requirement relates to the mandatory support of the IPM DL Functional Group, so as to include in the AMHS a functionality equivalent to that of PDAIs in the AFTN.

An important option, which is left as a matter of policy local to each AMHS Management Domain, is the question of the conformance to CCITT X.400. An AMHS Management Domain may be required to such conformance, e.g. under the following circumstances:

- a) to comply with national regulation when registration by the national registration authority is requested;
- b) to interconnect with public MHS ADMDs which are by definition CCITT X.400-84 or X.400-88 compliant.

If conformance to CCITT X.400 is required, this implies for the ATS Message Server the additional conformance to Profile AMH112. Support of AMH112 corresponds to the additional support of the mts-transfer-protocol and mts-transfer-protocol-84 application contexts, and to the support of the 84IW Functional Group.

A further consequence of the support of AMH112 is that the support of RTSE and ACSE in X.410-84 is then required.

### **2.2.3.2. Use of the Transport Service**

#### **2.2.3.2.1. Use of the ATN Transport Service**

An ATS Message Server by definition uses the ATN Transport Service to communicate with other ATS Message Server.

Several parameters need to be given to the transport service provider, when requesting a transport connection to be established. These parameters are specified in Sub-Volume 5.

For most of these parameters, a single value is selected, either in the SARPs or as a local matter, to be used when establishing a transport connection between two ATS Message Servers.

More specifically, the base MHS standards used in the CNS/ATM-1 Package SARPs do not allow for the establishment of different transport connections with different quality of service parameters, based on the distinction between application level MHS priorities. This is due to the absence of a QoS parameter in the MTA-Bind abstract-operation and in the RT-OPEN service. Thus a single transport priority, conveying messages with different application-level priorities is used.

The way to request the use of the specified parameters to the Transport Service provider is an implementation matter which is out of the scope of the SARPs.

#### **2.2.3.2.2. Use of the Transport Service for the AMH112 Profile**

If profile AMH112 is supported, then the ATS Message Server shall implement an ISO 8073 Class 0 Transport protocol. This cannot be implemented over the ATN, it is therefore out of the scope of the SARPs. However it is required, for example, if interconnection with a public X.400 ADMD is the local policy of a given AMHS Management Domain.

In such a situation, the co-existence of the support of Classes 0 and 4 of the ISO 8073 Transport protocol is an implementation matter, which out of the scope of the SARPs.

Furthermore, the parameters specified in 2.2.3.2.1 concerning the use of the ATN Transport Service are not applicable in such a context.

### **2.2.3.2. Logging functions at an ATS Message Server**

The SARPs specify the minimum logging requirements at an ATS Message Server. These long-term logging requirements are related to the administrative and legal requirement for the record of communications as specified in Annex 10, Volume II, 3.5. The SARPs requirements make it possible to perform message tracking through the AMHS, for example when an investigation is needed.

However, for an efficient management of the AMHS systems within one AMHS Management Domain, it could be useful to record more information, in particular about events not directly related to message transmissions but in relation with a good system operations.

The following events may be recorded for such management purposes:

- a) MTA-bind (to or from another MTA) operation successful completion;
- b) MTA-unbind (to or from another MTA); and
- c) MTA-bind (to or from another MTA) error.

The information recorded in relation with the events above may include the following parameters which are either arguments, results or errors of the abstract operations:

- a) initiator-name (if present);
- b) initiator-credentials (if present);
- c) security-context (if present);
- d) responder-name (if present);
- e) responder-credentials (if present); and
- f) bind-errors (if any).

Additionally, to maintain a traffic log reflecting the entire traffic flows through an ATS Message Server, and actions taken by an ATS Message Server, it may be required to record events related to the following events:

- a) Probe Submission operation (successful or error);
- b) Probe Transfer in successful operation;
- c) Probe Transfer out operation (successful or error);
- d) Message Submission error;
- e) Message Delivery error;
- f) Report Delivery error.

## **2.3. AFTN/AMHS GATEWAY DESCRIPTION**

### **2.3.1. General presentation**

The AFTN/AMHS Gateway has been conceived and designed as a technical tool to facilitate the transition from the world-wide AFTN to the new technology of ATS Message Handling Services over the ATN, namely the AMHS. To be useful, the gateway must be simple and reliable. It must also be easy to develop, deploy and maintain until it has achieved its purpose and has been withdrawn from use. Every effort has been directed towards developing a conceptual design that is fundamentally complete and does not attempt to correct AFTN deficiencies or to provide for services that are not absolutely required.

A gateway is a communication device that permits message traffic to be transferred between two dissimilar communication systems. The gateway must perform its special operations transparently to function as an ordinary device in each of the two interconnected communication systems.

The AFTN/AMHS gateway is a device that must live in two worlds at once; the AFTN and the AMHS. In order to achieve this it must have two essential characteristics: transparency and isolation. Transparency allows the gateway to hide the fact that it is a gateway altogether and to appear to be a normal member of the AFTN and of the AMHS. Isolation hides the existence of each messaging system from the other.

### **2.3.2. Functional decomposition**

The conceptual model used to define the requirements for the AFTN/AMHS gateway has been presented in Figure 2.2. This model provides an abstract view that facilitates the definition of the components of the gateway and the assignment of functions to each component. In addition, an AFTN/AMHS Gateway includes a control position which functions are a purely local matter and is therefore not represented on the diagram, since its relationship with the external world cannot be modelled.

The three major components of the gateway, the AFTN Component, the ATN Component and the message transfer and control unit, are interconnected as shown in Figure 2.2 to provide an architecture that assures isolation and transparency. The functions assigned to each component are presented in the following sections.

#### **2.3.2.1. AFTN Component**

The “access to AFTN” in Figure 2.2 represents a point of connection to an external AFTN Centre. Send and receive functions are incorporated into the gateway to establish a complete AFTN circuit connection to the AFTN Centre. The gateway must provide a sufficiently complete set of AFTN procedures to appear to be an ordinary AFTN Station. This imposes several special requirements and restrictions. Some functions in addition to those of an ordinary AFTN Station are necessary in the AFTN Component, due to its particular status as part of an AFTN/AMHS Gateway. However this does not alter the external appearance of the AFTN Component, as it may be seen from the AFTN Centre to which it is connected.

An AFTN address must be allocated to the AFTN Component, it is required in particular for the handling of the AFTN procedure between the AFTN Component and the AFTN Centre to which it is connected. Also to appear as an AFTN Station, this address is equally required.

Since the AFTN Component operates in a manner which is indistinguishable from an AFTN Station by the AFTN Centre to which it is connected, the AFTN Component is not required to have any diversion routing capability. Diversion routing is generally implemented in the AFTN Centre to which the AFTN/AMHS Gateway is connected. An implication of this situation is that an AFTN/AMHS Gateway is connected to a single AFTN Centre, if communicating with the AFTN side through an AFTN circuit.

However, from an implementation viewpoint, it is likely that in many occasions an AFTN/AMHS Gateway will be co-located with an AFTN Centre. Such a co-location may also be logical, which means that the AFTN/AMHS Gateway and the AFTN Centre do not communicate through an AFTN circuit, but rather using ad-hoc procedures eg. on a local area network. In such a case, some of the functions specified for the AFTN Component may not be required (eg. discarding of channel-check transmissions). It is then sufficient that:

- a) the co-located AFTN Component and the AFTN Centre together fulfill the required functions;
- b) the AFTN Component provides the Message Transfer and Control Unit of the AFTN/AMHS Gateway with an interface identical to that specified in the SARPs.

#### **2.3.2.2. ATN Component**

The ATN Component allows the gateway to function as an end system on the ATN. For this purpose, it incorporates an MTA in a manner equivalent to that of an ATS Message Server.

This MTA must implement the DL Functional Group, in compliance with the ATS Message Server specification. If the AMHS Management Domain operating the AFTN/AMHS Gateway additionally desires to implement other optional Functional Groups, this may be done in the ATN Component. For example, the ATN Component is the part of an AFTN/AMHS Gateway where the AMHS rerouting and/or redirection capability of the gateway, if any, is implemented.

#### **2.3.2.3. Message Transfer and Control Unit**

The remaining component, as shown in Figure 2.2, is named the “Message Transfer and Control Unit”. In an AFTN/AMHS Gateway, this is the MHS Access Unit (AU) which provides application level functions that are not part of either the AFTN Component or of the ATN Component. These functions bind and integrate the other two components and are essential to the operation of the gateway. They include:



- a) general functions, which themselves cover two main subjects:
  - 1) traffic logging,
  - 2) address look-up tables which include the information necessary for the address conversion process between the two address spaces of the AMHS and of the AFTN to be performed;
- b) AMHS to AFTN conversion, for the conversion of information objects received from the AMHS for potential conveyance in the AFTN. Because the AMHS level of functionality is higher than that of the AFTN, this function includes all the necessary processing to determine the gateway ability to convert the information object, and the necessary actions related to the potential rejection if the AFTN cannot convey the received information object;
- c) AFTN to AMHS conversion, for the conversion of messages received from the AFTN for potential conveyance in the AMHS. For isolation purposes, the AFTN/AMHS Gateway converts in an automated manner only those AFTN service messages which have an end-to-end significance and which have an equivalent in the AMHS.

Although it communicates with the ATN Component through a P1-interface (see 2.3.2.5), the Message Transfer and Control Unit is not required to implement the functionalities associated with any of the optional functional groups defined in the ISP. More specifically the MTCU is not supposed to perform any DL-expansion. If supported in an AFTN/AMHS Gateway, such functionalities are implemented in the ATN Component, which incorporates a MTA equivalent to that of an ATS Message Server.

#### **2.3.2.4. Other components**

Each gateway also includes an operator control position, or other input-output devices to accomplish the same function. The control position provides a method to load, initialize and control the operation of the gateway. The terminal is also used to display or record transient conditions, including error reports related to the gateway processing.

The control position therefore provides an operator interface where exception cases which could not be handled in an automated manner by the AFTN/AMHS Gateway components, may be handled and reacted upon. Also, it is a matter of policy local to the AMHS Management Domain operating the AFTN/AMHS Gateway, to decide whether certain categories of exception cases are handled automatically or with the assistance of the control position.

The format used by the AFTN Component, the ATN Component and the Message Transfer and Control Unit of an AFTN/AMHS Gateway to report errors to the control position is a matter of policy local to the AMHS Management Domain operating the AFTN/AMHS Gateway. Such errors are usually associated with a specification in the SARPs that an information object is to be automatically discarded. For a better interpretation of the error situation at the control position, the subject information object may be sent in conjunction with the error reported to the control position.

For some categories of error situations the SARPs specify the actions to be taken, e.g. message rejection and generation of an appropriate service message (to the AFTN) or non-delivery report (to the AMHS). The specified actions aim at minimizing the assistance of the control position. However it may be a matter of policy local to the AMHS Management Domain operating an AFTN/AMHS Gateway to try to reduce the occurrence of message rejection with the assistance of the control position.

#### **2.3.2.5. Interface between the ATN Component and the Message Transfer and Control Unit**

The exchange of information at the interface between the ATN Component and the Message Transfer and Control Unit is made using Transfer Envelopes, i.e. P1-envelopes.

Other specifications are possible for an MHS AU. In particular, the selection of a Submission/Delivery interface would also have been possible. The reason to select a P1 interface is the possibility which is then given to the Message Transfer and Control Unit to generate non-delivery reports and delivery-reports. Such a possibility would not have been available if a P3 interface had been selected. The ability to generate NDRs is considered particularly useful for the mapping certain AFTN service messages, i.e. those which indicate that the specified message recipient is unknown.

In terms of implementation, a P1-API may then be used between the ATN Component and the Message Transfer and Control Unit when developing an AFTN/AMHS Gateway.

Flow control mechanisms may be implemented in both directions between the gateway components, e.g. to ensure that no messages in excess are passed to the ATN Component when it is unable to transfer them to the ATS Message Server or AFTN/AMHS Gateway to which it is connected. Such mechanisms, including the triggering criteria, are an implementation matter which is out of the scope of the SARPs.

#### **2.3.2.6. Interface between the AFTN Component and the Message Transfer and Control Unit**

Likewise, the Message Transfer and Control Unit has the possibility in an AFTN/AMHS Gateway to construct AFTN Service Messages with end-to-end significance and to pass them over to the AFTN Component, upon receipt of a NDR indicating an unknown recipient specification in a subject message.

As mentioned above, flow control mechanisms may also be implemented in both directions between these gateway components, e.g. to ensure that no messages in excess are passed to the AFTN Component when it is unable to transfer them to the AFTN Centre to which it is connected. Such mechanisms, including the triggering criteria, are an implementation matter which is out of the scope of the SARPs.

#### **2.3.3. Traffic Logging in an AFTN/AMHS Gateway**

In general, the way in which the information specified is logged is an implementation matter. The way in which the information is retrieved and used is an implementation and operational matter. Therefore such aspects are out of the scope of the SARPs.

##### **2.3.3.1. AFTN Component traffic logging**

This function is where the behaviour of the AFTN Component differs from that of an AFTN Station.

Upon reception of a message from the AFTN, the AFTN Component behaves as an AFTN Station.

Upon generation of an AFTN message in the AFTN Component, long-term retention of the message in its entirety is performed in the AFTN Component. This may only happen for service messages, since otherwise the AFTN Component is not supposed to generate any message.

Messages received by the AFTN Component from the Message Transfer and Control Unit do not need to be logged in their entirety since the AFTN Component is not the initial originator of the message. Therefore, in this case, the logging requirement placed on the AFTN Component is equivalent to that of an AFTN Centre, that is to retain only the message heading, address and origin parts, and the action taken thereon.

##### **2.3.3.2. ATN Component traffic logging**

The traffic logging to be performed in the ATN Component of an AFTN/AMHS Gateway is equivalent to that of an ATS Message Server.

### **2.3.3.3. Message Transfer and Control Unit traffic logging**

The main goal of the logging to be performed in the Message Transfer and Control Unit is to keep track of all information objects which have passed through the Message Transfer and Control Unit, and in particular to be able to identify the relationship between e.g. a received AMHS message and the converted AFTN message, for traceability purposes.

In case of duplication of information with either the traffic log of the ATN Component or of the AFTN Component, there is no requirement to implement different logs, provided that adequate mechanisms are implemented to allow the use of these traffic logs by the Message Transfer and Control Unit or in relation with the Message Transfer and Control Unit.

The nature of the information which is logged (and the way in which it is logged) in case of error situations in the Message Transfer and Control Unit is an implementation matter which depends on the way such situations are handled on a local basis.

### **2.3.3.4. Relationship between these traffic logs**

In implementation terms, it is not necessary to implement three different logs in an AFTN/AMHS Gateway. In case of duplication of information between the Message Transfer and Control Unit traffic log and either the traffic log of the ATN Component or of the AFTN Component, it is only necessary that adequate mechanisms are implemented to allow the use of these traffic logs by the Message Transfer and Control Unit.

### **2.3.4. Address conversion in an AFTN/AMHS Gateway**

An AF-address may be converted in two different manners in an AFTN/AMHS Gateway:

- a) if a corresponding MF-address including any combination of O/R address attributes has been allocated to the user identified by the AF-address, then a mapping process using fully configured look-up tables is necessary;
- b) if no such address has been allocated, then the default conversion process for such an AF-address in an AFTN/AMHS Gateway (or more specifically in the Message Transfer and Control Unit of an AFTN/AMHS Gateway) aims at converting the AF-address into an XF-address, by means of a partly algorithmic method.

Case b) may occur for both indirect or direct users. In such a case, a look-up table is still necessary to identify the AMHS Management Domain to which the user belongs.

The term look-up table is used above and in the SARPs to describe in a simple manner the role of the function. However, many solutions can be envisaged when implementing such a function. For example, it is not necessary to implement two different look-up tables for the two mapping processes.

Also other types of data structures, e.g. databases, may be used to implement the required function.

### **2.3.5. Conversion functions of an AFTN/AMHS Gateway**

These functions are performed by the Message Transfer and Control Unit. In the SARPs, the specification of these functions is split in accordance with the flow direction through the AFTN/AMHS Gateway. The conversion function in the direction from AFTN to AMHS is specified in section 3.1.2.3.4 of the SARPs and the conversion function in the direction from AMHS to AFTN is specified in section 3.1.2.3.5 of the SARPs.

The entire set of information objects processed by an AFTN/AMHS Gateway, together with the section of the SARPs where the relevant processing is specified, is depicted in Figure 2.7.

**Figure 2.7 : Information objects processed by the gateway**

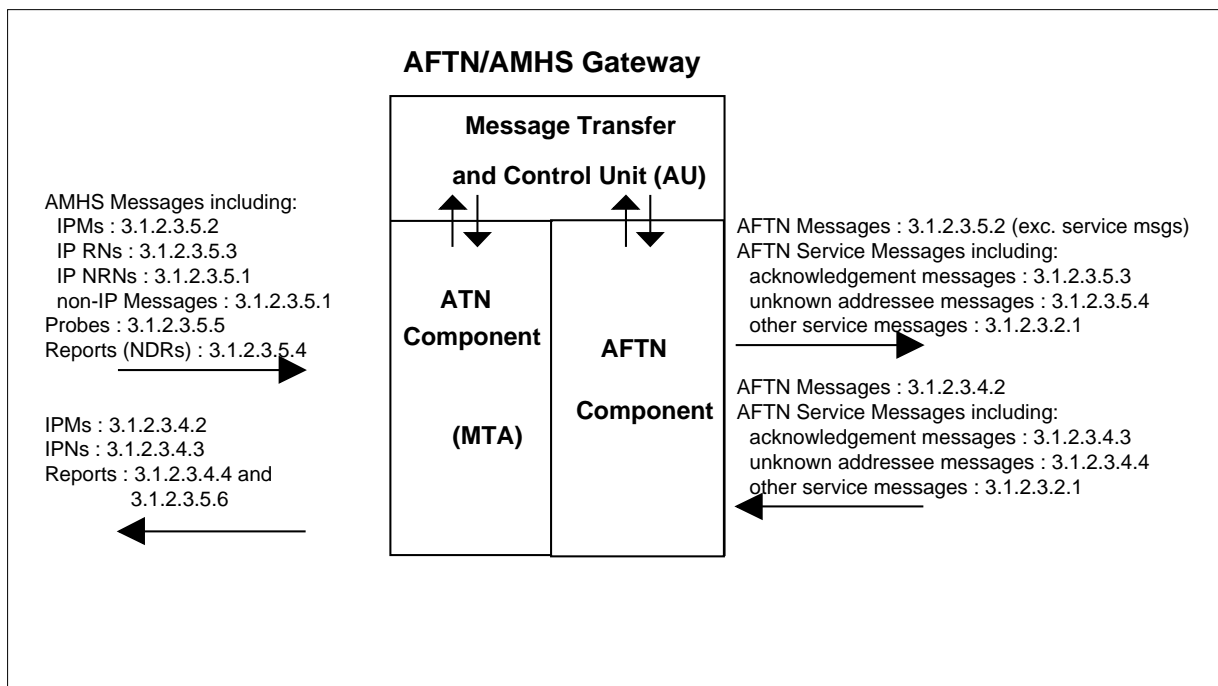

### 2.3.5.1. AFTN to AMHS Conversion

#### 2.3.5.1.1. Converted information objects

In this direction, the way to process the message may be determined from the contents of the first line of the message text. This first line refers to the string of characters included between the first character in a message text and the first CARRIAGE RETURN found therein.

An acknowledgement message is characterized by its text which includes exclusively "R ddhmm AFADDRES", where ddmmhh is a filing time as defined in Annex 10, Vol. II, 4.4.16.2.2.1 and AFADDRES is an AF-address.

An AFTN service message indicating that an addressee indicator in the subject message is unknown is characterized by its text which includes "SVC ADS ddhmm AFADDRES", where ddmmhh is a filing time as defined in Annex 10, Vol. II, 4.4.16.2.2.1 and AFADDRES is an AF-address.

All other AFTN service messages are handled in the AFTN component only. In the particular case of AFTN service messages requesting correction by the originator of a message received mutilated, such messages are handled on the basis of a local specification, since no automated process can be specified due to:

- the difficulty to determine in an automated manner whether the AFTN/AMHS Gateway is in possession of an unmutilated copy of the message, and
- to the absence of an equivalent message in the MHS base standards. In effect, message mutilation, if it occurs in the AMHS, is automatically detected during the conveyance and reacted upon by means of MHS protocols; there is thus no need to request repetition from the originator.

### **2.3.5.1.2. Guidance on error situations**

Error situations may be reported for further actions to the control position in the following cases:

- a) in case of conversion failure (general) in the MTCU or in case of transfer failure between the MTCU and the other components (3.1.2.3.4.1.3);
- b) if the originator indicator of an AFTN message cannot be converted into an MF-Address (nor into an XF-Address) (3.1.2.3.4.2.1.4.1);
- c) in case of reception of an AFTN service message referring to a subject AFTN message which has not passed through the AFTN/AMHS Gateway (3.1.2.3.4.3.1.1, 3.1.2.3.4.4.1.1);
- d) in case of reception of an AFTN acknowledgement message for an IPM received without RN request;
- e) in case of reception of an AFTN unknown addressee service message where the unknown addressee indicator cannot be determined or mapped into a MF-Address (3.1.2.3.4.4.1.2, 3.1.2.3.4.4.1.3);
- f) in case of reception of an AFTN unknown addressee service message relative to a subject message which already caused the generation of a delivery-report by the AFTN/AMHS Gateway (3.1.2.3.4.4.1.4).

In each of these cases, guidance may be given about the actions to be undertaken at the control position. TO BE FURTHER DEVELOPED

### **2.3.5.2. AMHS to AFTN Conversion**

#### ***2.3.5.2.1. Converted Information objects***

The processing applied to a received AMHS information object by the Message Transfer and Control Unit is either of the following, depending on the category of information object (message, probe or report) and content-type (interpersonal messaging, other):

- a) process the object for conversion, or at least for further testing aiming at the determination of the gateway ability to convert the object based on envelope or contents parameter values,
- b) rejection of the object, and generation of a non-delivery report, or
- c) discard the message and report of an error situation. Such an event cannot normally happen under normal operating circumstances.

In the Basic ATS Message Service, only the IPM content-type is supported. Thus edi-messaging (35) content type messages are rejected by an AFTN/AMHS Gateway.

Delivery reports are discarded by the Message Transfer and Control Unit as described in c) above. This is due to the fact that an Message Transfer and Control Unit requests non-delivery-reports, but never delivery-reports when generating AMHS messages.

For IP Messages, the only body part types supported by the Message Transfer and Control Unit in reception are the following:

- a) basic ia5-text,
- b) basic message (if the forwarded message initially was an IPM),
- c) extended ia5-text-body-part,
- d) extended general-text-body-part,
- e) extended message-body-part (if the forwarded message initially was an IPM).

Cases b) and e) may result of a subject IPM having been forwarded at a receiving AMHS UA, or sequentially forwarded at several UAs. In the latter case the innermost content is used to determine if the initial message was an IPM.

#### 2.3.5.2.2. Behaviour upon receipt of non-delivery reports

When a non-delivery report is received from the AMHS, this report is discarded unless its non-delivery-diagnostic-code is "unrecognised-OR-name" (re. 3.1.2.3.5.1.3).

Within the AMHS MD managing an AFTN/AMHS Gateway, a local policy may be established to handle such situations, either in an automated manner or at the gateway control position:

- a) repeat the subject message a certain number of times, within time intervals to be determined, and depending on the report non-delivery-reason-code and non-delivery-diagnostic-code; or
- b) inform the originator, using a plain text AFTN message, that the subject message could not be delivered; or
- c) a combination of a) and b) above if a) is unsuccessful.

#### 2.3.5.2.3. Guidance on error situations

Error situations may be reported for further actions to the control position in the following cases:

- a) if a NRN is received (3.1.2.3.5.1.2);
- b) if the received information object is not among the objects to be converted, nor within the objects to be explicitly rejected (3.1.2.3.5.1.5, last resort rejection);
- c) if a message is received which priority-indicator in the ATS-Message-Header is "SS" and which does not request a RN (3.1.2.3.5.2.3.3);
- d) if a RN is received relative to a subject IPM which had not been generated by the AFTN/AMHS Gateway (3.1.2.3.5.3.1.1);
- e) if a RN is received relative to a subject IPM which priority-indicator in the ATS-Message-Header differs from "SS" (3.1.2.3.5.3.1.1); and
- f) if a NDR is received relative to a subject IPM which had not been generated by the AFTN/AMHS Gateway (3.1.2.3.5.4.1.1).

In each of these cases, guidance may be given about the actions to be undertaken at the control position. *TO BE FURTHER DEVELOPED*

### **3. ATN PASS-THROUGH SERVICE GUIDANCE**

to be developed

## APPENDIX A : DEFECT REPORT ON GROUND-GROUND APPLICATION SARPS

### DEFECT REPORT ON SARPS

Defect Number (to be supplied by SARPs Editor):		
SARPs affected (Sub-Volume and Part):		SARPs Version/Date:
Originator Name:		
Originator Reference:		
Date Raised:		
Location of Defect (including Section Number):		
Summary of the Defect:		
Proposed solution of assumptions made (if any):		
Editor's Comment:		
Date of Resolution:		
SARPs Version/Date where defect is closed:		



