

AERONAUTICAL TELECOMMUNICATIONS NETWORK PANEL
WORKING GROUP 2

Alexandria Old Town, USA 7-15 October 1996

Appendix G to WG2-9/WP340
- European ATN Validation Report -

**An example of a Validation Exercise conducted in
the frame of the « EURATN » Experiments**

AVE_307 : Shortest path update with IDRP

Prepared by Christine Ricci and Stéphane Tamalet

Presented by Jean-Michel Crenais

(STNA - French DGAC)

SUMMARY

This Document has been issued in the frame of the European co-operative validation effort in order to detail and explain how validation exercises were conducted with the « EURATN » validation tool.

The first part of the document is identical to Appendix G of WG2-9/WP340 (European ATN Validation Report), and the second part, i.e. Annex 4, gives a description of one specific Validation Exercise.

The selected exercise is AVE_307 : Shortest path update with IDRP.

TABLE OF CONTENTS

1. INITIATIVE REFERENCE AND TITLE	3
2. TYPE.....	3
3. RESPONSIBLE STATE/ORGANISATION.....	3
4. CONTACT POINT	3
5. PARTICIPATING STATES/ORGANISATIONS.....	3
6. VALIDATION TOOLS INVOLVED.....	4
7. VALIDATION PERIODS.....	4
8. DESCRIPTION.....	5
8.1 GENERAL.....	5
8.2 RESULTS.....	5
9. REFERENCES.....	5
<i>8.1.3 Traffic Profiles.....</i>	<i>30</i>
<i>8.1.4 Points of observation.....</i>	<i>31</i>
<i>8.1.5 Network Operator Action</i>	<i>31</i>
<i>8.1.6 Test sequencing.....</i>	<i>31</i>
<i>8.1.7 Expected Results</i>	<i>31</i>

Annex 1: Validation Objectives Coverage

Annex 2: Validated sections of the ATN Internet SARPs

Annex 3: Raised issues - Recommendations

Annex 4: Example of a detailed results analysis document: AVE_307

1. Initiative Reference and Title

« EURATN » : The « EURATN » EXPERIMENTS

2. Type

Experimentation

3. Responsible State/Organisation

French DGAC

4. Contact Point

State/Organisation	Contact Details
French DGAC	Mrs Christine Ricci STNA/8CA 1, avenue Dr Maurice Grynfogel BP 1084 31055 Toulouse Cedex FRANCE Tel: +33 62 14 54 82 FAX: +33 62 14 53 53 e-mail: ricci_christine@cmail.dgac.fr

5. Participating States/Organisations

France (DGAC),
EUROCONTROL (Specification phase)
EURATN consortium (Specification Phase)

State/Organisation	Contact Details
EurATN consortium	Dr K.P. Graf, ESG Einsteinstrasse 174 D-81675 München, GERMANY Tel: +49 89 92 162742 Fax: +49 89 92 162632
Eurocontrol	Mr. Henk Hof Rue De La Fusee 96 B-1030 Brussels, Belgium Tel: + 32 2 729 3329 Fax: + 32 3 729 9083 Internet: henk.hof@eurocontrol.be

6. Validation Tools Involved

The experiments were conducted on the EURATN demonstrator, version 2.0.

The physical topology of the demonstrator consists of 7 workstations, located on two different sites, CENA/Toulouse and CENA/Athis-Mons. These workstations can be interconnected via Ethernet LANs or X.25 PSDN (SITA or FT TRANSPAC). In this topology, each workstation can be configured to act as any of the following EURATN systems: ES, IS, Ground/Ground BIS, Air/Ground BIS, ES/BIS (ES and BIS), ES/IS (ES and intra-domain IS). The kinef workstation can be configured to act as an Airborne BIS, due to the real satellite equipment installed on the demonstrator

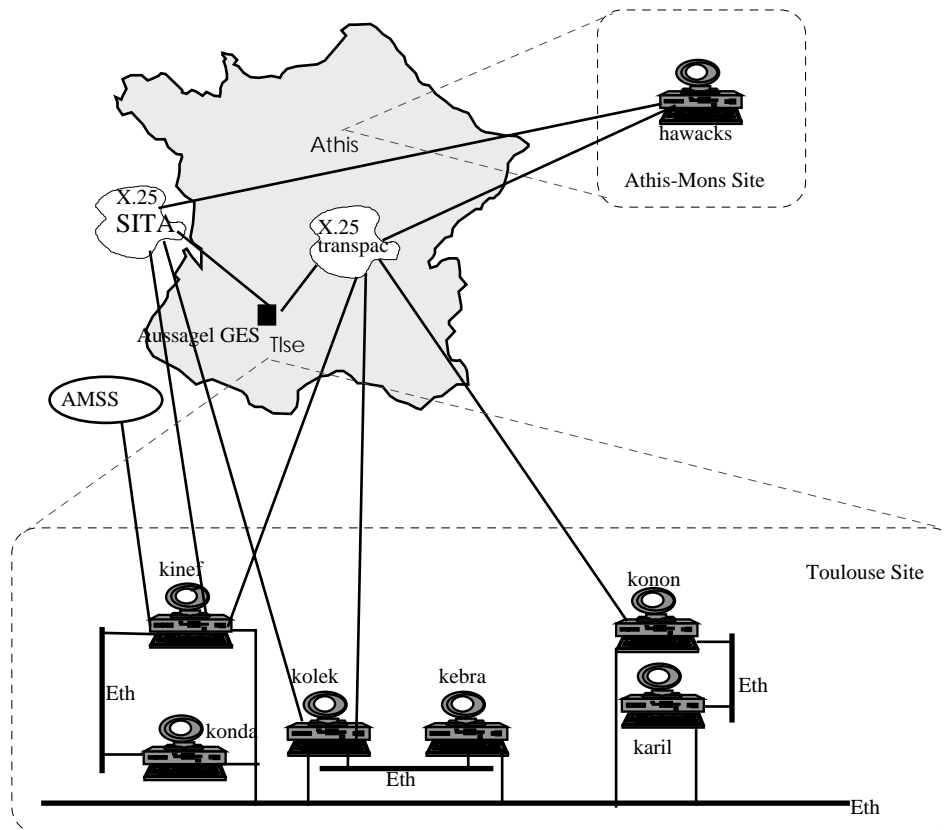

7. Validation Periods

The « EURATN » validation exercises are aimed at validating the main aspects of the ATN Internet SARPs (REF[1]) via a set of experiments that can be conducted on the EURATN demonstrator. They were first specified in the frame of the EURATN project during 1995 (see REF[2], REF[3] and REF[4]).

A final update to these specifications has been produced by STNA in May 1996 in the form of two documents: High-level specifications of « EURATN » Validation Exercises (STNA/8CA/VAL/DOC_01), and Detailed specifications of « EURATN » Validation Exercises (STNA/8CA/VAL/DOC_02).

The exercises have been conducted on the EURATN demonstrator at CENA/Toulouse and Athis-Mons from July to mid-August 1996.

The results of the exercises have been analyzed in September 1996, and led to the production of 15 detailed analysis documents entitled « Result of Validation Exercise AVE_xxx » (STNA/8CA/VAL/AVE_xxx), out of which the results described in the present Validation Report have been extracted.

8. Description

8.1 General

EURATN is an ATN Experimental Network, and includes a wide set of ATN systems, i.e. ATN ES (including Connection-Oriented and Connectionless-Mode Transport Generator), ATN intra-domain IS, ATN Ground/Ground BIS, ATN Air/Ground BIS, and ATN Airborne BIS with or without IDRP. The aim of the EURATN validation experiments is to take advantage of this experimental network to check the correct behaviour of an ATN Internet in a large variety of situations.

The experiments have been developed in the context of the following four main validation domains:

- Intra-domain Ground/Ground routing
- Inter-domain Ground/Ground routing
- Inter-domain Air/Ground Routing
- Properties and Performances

8.2 Results

For each exercise conducted in the frame of this validation initiative, an archive has been created on the ATN Validation Archive. This archive contains a document constituting the detailed analysis of the exercise (« Results of Validation Exercise AVE_xxx »), and a complete archive of the EURATN configuration files and traces of the exercise.

Concerning ATN Internet SARPs Validation, the main results of this set of exercises are summarized below:

- None of the issues that have been raised by the « EURATN » validation exercises did result in a major Defect Report on the ATN Internet SARPs.
- All the minor defects raised by the « EURATN » validation exercises have been reported to ATNP/WG2. They have found a solution either in the form of a Change Proposal to the ATN Internet SARPs, either in the form of a recommendation concerning the ATN Internet Guidance Material (see Annex 3 for the detailed list of the encountered issues and resolution proposal).

As a consequence, we are confident in the fact that there are no major defects in the domains of the ATN Internet SARPs addressed by these « EURATN » validation experiments (see Annexes 1 and 2).

The coverage by this validation initiative of the Validation Objectives is described in Annex 1. The list of the ATN Internet SARPs items validated by this initiative is presented in Annex 2.

9. References

- REF1: ATN SARPs - Sub-Volume 5 - Internet Communications Service
- REF2: EURATN: ATN Validation Exercise - High-level Specifications of CNS/ATM-1 Package SARPs Validation Exercises, Parts 1, 2 and 3 (SOF_4.0_WD_02)
- REF3: EURATN: ATN Validation Exercise - High-level Specifications of CNS/ATM-1 Package SARPs Validation Exercises, Parts 4 and 5 (ESG_4.0_WD_03)
- REF4: EURATN: ATN Validation Exercise - Detailed Specifications of CNS/ATM-1 Package SARPs Validation Exercises (SOF_4.0_WD_05)
- REF5: High-level specifications of « EURATN » Validation Exercises (STNA/8CA/VAL/DOC_01).
- REF6: Detailed specifications of « EURATN » Validation Exercises (STNA/8CA/VAL/DOC_02).
- REF7: CNS/ATM-1 Package Internet SARPs Validation Objectives (DED1/ATNIP/STA/DOC/008)
- REF8 to REF23: Result of Validation Exercise AVE_xxx (STNA/8CA/VAL/AVE_xxx)

Annex 1: Validation Objectives Coverage

AVO Name	VE Name	AVO Text
AVO_201	AVE_308 AVE_206 AVE_307 AVE_304 AVE_305 AVE_302 AVE_303 AVE_407 AVE_505 AVE_506 AVE_507	<p>Verify that two compliant ATN End Systems interoperate and provide Connection-Oriented Transport Service to Transport Service users. These End Systems should be configured so as to obey a default ATN profile (subsequent validation exercises will investigate different profile combinations). The exercise(s) based on that objective should address: connection establishment, one-way data transfers, two-way data transfers, expedited data transfer, normal disconnection, multiple simultaneous connections. Note: several experiments will have this exercise as a prerequisite. Data transfers will be used to test various network conditions and to exercise ATN systems.</p> <p>Covered.</p>
AVO_204	AVE_206 AVE_307 AVE_302 AVE_303 AVE_304 AVE_305 AVE_308 AVE_306 AVE_407 AVE_408 AVE_505 AVE_506	<p>Verify that two compliant ATN End Systems interoperate and provide the Transport Service across multiple subnetworks. Multiple subnetwork configurations should include: a) one LAN - n ground point-to-point links (or WAN) - one LAN b) one LAN - n ground point-to-point links (or WAN) - Mode S - one LAN c) one LAN - n ground point-to-point links (or WAN) - Satellite - one LAN d) one LAN - n ground point-to-point links (or WAN) - VHF - one LAN</p> <p>a) and c) have been covered by the exercises, with no issue encountered</p>
AVO_205	AVE_206 AVE_305 AVE_302 AVE_303 AVE_304 AVE_307 AVE_308 AVE_306 AVE_406 AVE_407 AVE_505	<p>Verify that ground-ground BISs from different Routing Domains with different IDRP/CLNP profiles stating compliance to the ATN Draft SARPs can interwork at the functional level. This objective is meant to verify the various aspects of the BIS-BIS communication: connection establishment, routing update, route advertisement, route refresh, disconnection.</p> <p>Covered, except for Route Refresh</p>
AVO_206	AVE_206 AVE_302 AVE_307 AVE_308 AVE_505	<p>Verify that ground-ground BISs belonging to the same Routing Domain with different IDRP/CLNP profiles stating compliance to the ATN Draft SARPs can interwork at the functional level. This objective is meant to verify the various aspects of the BIS-BIS communication: connection establishment, routing update, route advertisement, route refresh, disconnection. It verifies also the features specific to domain internal BIS-BIS communications.</p> <p>Covered, except for Route Refresh (not tested)</p>
AVO_230	AVE_206 AVE_305 AVE_301 AVE_302 AVE_303 AVE_304 AVE_306 AVE_307	<p>Verify the ground-ground BIS interworking, as in the previous objective, for various subnetwork adjacencies: LAN, point-to-point links, multiple intra-domain hops, etc.</p> <p>Covered.</p>

	AVE_308 AVE_505	
AVO_233	AVE_401 AVE_404 AVE_406 AVE_407 AVE_505	Verify that air-ground and airborne BISs with different IDRP/CLNP profiles stating compliance to the ATN Draft SARPs can interwork at the functional level for subnetworks providing polled-mode routing initiation mechanisms. This objective is meant to verify the various aspects of the BIS-BIS communication: route initiation, connection establishment, routing update, route advertisement, route refresh, disconnection. Covered , except for Route Refresh (not tested)
AVO_234	AVE_403 AVE_406 AVE_408	Verify that air-ground and airborne BISs supporting the non-use of IDRP option can interwork at the functional level for subnetworks providing polled-mode routing initiation mechanisms. This objective is meant to verify the various aspects of the BIS-BIS communication: route initiation, ISH monitoring. Covered
AVO_240	AVE_303 AVE_307 AVE_308 AVE_304 AVE_305	Verify that data packets follow alternate paths and maintain communication after failure of a network component. Covered . See Annex 3 item 2)b for raised issue
AVO_241	AVE_206 AVE_307 AVE_301 AVE_308 AVE_302 AVE_303 AVE_404 AVE_406 AVE_407 AVE_505	Verify that BISs can sustain BIS-BIS connections for a long period of time to support a 'typical' routing information exchange. Typical routing traffic include a) asymmetric traffic, e.g. peripheral BIS towards backbone BIS, and b) symmetric traffic, e.g. between backbone BISs Covered partially (depends of what a long period of time is).
AVO_242	AVE_307 AVE_308 AVE_404 AVE_406 AVE_407 AVE_505	Verify the ability of the IDRP protocol to choose the better route for a given criteria (minimal distance). Covered
AVO_243	AVE_307 AVE_308 AVE_404 AVE_406 AVE_407 AVE_505	Verify the stability of the IDRP: ability of IDRP to converge in the updating of the routing table in sufficient time to avoid loss of transport connections, and to maintain end-to-end QoS. Covered . Depends on the Transport Timers setting
AVO_244	AVE_404 AVE_401 AVE_406 AVE_407	Verify that routes to mobile domains are propagated in an ATN network in such a way that all aircraft remain reachable from any domain. Covered partially (limited to the demonstrator capacity in terms of systems)
AVO_247	AVE_404 AVE_406 AVE_407 AVE_505	Verify that Routing Policy Rules in the air/ground environment guarantees proper dissemination of route information. Covered partially
AVO_303	AVE_305 AVE_303 AVE_304	Verify the ability of the ATN service to ensure a fall back on another sub-network in case of problem on the default sub-network. Not Covered. But the raised issue is not a problem of SARPs. (see annex 3 item 2)b)
AVO_304	AVE_407	Verify that perturbed
AVO_311	AVE_407	Verify that the ATN can deliver homogeneous, continuous and efficient service to the user from take-off to landing Covered partially

AVO_409	AVE_306 AVE_301	Evaluate the reliability of the IDRPs transport mechanism (number of retransmissions, transmission errors) Covered, partially
AVO_421	AVE_407 AVE_408	Show that it is possible to maintain communication between any ground system and an aircraft following a realistic flight path. Covered partially
AVO_422	AVE_407	Show that when there is a change in the route to an aircraft, the time taken between the loss of communication and the establishment of a replacement communications path neither results in the loss of a transport connection between the ground system and aircraft, nor does the transit delay increase beyond an acceptable minimum QoS. Covered partially
AVO_424	AVE_407	Verify the reliability of the service during mobile subnetworks handover conditions. Covered Partially.
AVO_429	AVE_406	Evaluate the impact on IDRPs of additional subnetwork connections between an air/ground and an airborne router, and the handover from one air/ground router to another. Covered Partially: Only handover between one Satellite GES and another has been tested
AVO_441	AVE_505 AVE_506	Evaluate end-to-end QoS (e.g. Transport Service QoS as defined in ISO/IEC 8072) for relevant network configurations. Covered Partially
AVO_443	AVE_505	Evaluate the impact of the traffic load on the QoS. Covered Partially
AVO_444	AVE_506 AVE_507	Evaluate the service characteristics in terms of : - measurement of packet lost number - data integrity - number of retransmissions Covered Partially

Annex 2: Validated sections of the ATN Internet SARPs

The following sections of the CNS/ATM-1 Package Sub-Volume 5 SARPs have been covered by the DGAC EURATN Experiments:

SARPS SECTIONS	COVERAGE
5.1 INTRODUCTION	N/A
5.2 DEFINITIONS AND CONCEPTS	N/A
5.3 ATN ROUTING	PARTIAL
5.3.1 INTRODUCTION	N/A
5.3.2 SERVICE PROVIDED BY AN ATN ROUTER	PARTIAL
5.3.2.1 <i>General</i>	N/A
5.3.2.2 <i>Forwarding CLNP NPDU's</i>	<i>partial</i>
5.3.2.2.1 <i>General</i>	yes
5.3.2.2.2 <i>Forwarding a CLNP NPDU when no Security Parameter is present in the PDU Header</i>	yes
5.3.2.2.3 <i>Forwarding a CLNP NPDU when a Security Parameter is present in the PDU Header</i>	no
5.3.3 THE DEPLOYMENT OF ATN COMPONENTS	PARTIAL
5.3.3.1 <i>Interconnection of ATN RDs</i>	<i>partial</i>
5.3.3.1.1 <i>General</i>	yes
5.3.3.1.2 <i>Interconnection between Members of an ATN Island Backbone RDC</i>	no
5.3.3.1.3 <i>Interconnection between Members of an ATN Island Backbone RDC and other ATN RDs within the ATN Island</i>	no
5.3.3.1.4 <i>Interconnection of ATN Islands</i>	no
5.3.3.1.5 <i>Interconnection of Mobile and Fixed RDs</i>	yes
5.3.3.1.6 <i>Interconnection of ATN RDs and non-ATN RDs</i>	N/A
5.3.4 GROUND/GROUND INTERCONNECTION	PARTIAL
5.3.4.1 <i>Interconnection Scenarios</i>	N/A
5.3.4.2 <i>Ground/Ground Route Initiation</i>	yes
5.3.4.3 <i>Ground/Ground Routing Information Exchange</i>	<i>partial</i>
5.3.4.4 <i>Ground/Ground Route Termination</i>	yes
5.3.5 AIR/GROUND INTERCONNECTION	PARTIAL
5.3.5.1 <i>Interconnection Scenarios</i>	N/A
5.3.5.2 <i>Air/Ground Route Initiation</i>	<i>partial</i>
5.3.5.2.1 <i>General</i>	N/A
5.3.5.2.2 <i>Route Initiation Procedures for a Responding ATN Router</i>	<i>partial</i>
5.3.5.2.2.1 <i>General</i>	yes
5.3.5.2.2.2 <i>Emergency Use of a Mobile Subnetwork</i>	no
5.3.5.2.3 <i>Air-Initiated Route Initiation</i>	<i>partial</i>
5.3.5.2.3.1 <i>Airborne Router Procedures for use of an ISO/IEC 8208 Mobile Subnetwork that does not Provide Information on Subnetwork Connectivity</i>	yes
5.3.5.2.3.2 <i>Airborne Router Procedures for use of an ISO/IEC 8208 Mobile Subnetwork that does Provide Connectivity Information</i>	no
5.3.5.2.4 <i>Ground-Initiated Route Initiation</i>	no
5.3.5.2.5 <i>Air or Ground-Initiated Route Initiation</i>	no
5.3.5.2.6 <i>Exchange of Configuration Information using the ISO/IEC 9542 ISH PDU</i>	yes
5.3.5.2.7 <i>Validation of the Received NET</i>	no
5.3.5.2.8 <i>Determination of the Routing Information Exchange Procedure by an Air/Ground Router</i>	yes
5.3.5.2.9 <i>Determination of the Routing Information Exchange Procedure by an Airborne Router</i>	yes
5.3.5.2.10 <i>Establishment of a BIS-BIS Connection</i>	yes

5.3.5.2.11 Exchange of Routing Information using IDRP	yes
5.3.5.2.12 Procedures for the Optional Non-Use of IDRP over an Air/Ground Data Link	yes
5.3.5.2.13 Air/Ground Route Termination	yes
5.3.5.2.14 APRL for Air/Ground Route Initiation	N/A
5.3.6 HANDLING ROUTING INFORMATION	NO
5.3.7 POLICY BASED SELECTION OF ROUTES FOR ADVERTISEMENT TO ADJACENT RDS	NO
5.4 NETWORK AND TRANSPORT ADDRESSING SPECIFICATION	YES
5.5 TRANSPORT SERVICE AND PROTOCOL SPECIFICATION	PARTIAL
5.5.1 GENERAL	YES
5.5.2 CONNECTION MODE TRANSPORT LAYER OPERATION	PARTIAL
5.5.2.1 Connection Mode Transport Service Primitives	yes
5.5.2.2 ATN Specific Requirements	yes
5.5.2.3 Connection Mode Transport Quality of Service	yes
5.5.2.4 Encoding of Transport Protocol Data Units	partial
5.5.2.4.1 General	yes
5.5.2.4.2 Encoding of the Acknowledgment Time Parameter	no
5.5.2.5 Transport Layer Congestion Avoidance	no
5.5.2.6 Use of the ATN Network Service	yes
5.5.2.7 Connection Mode Transport APRL	N/A
5.5.3 CONNECTIONLESS MODE TRANSPORT PROTOCOL OPERATION	YES
5.6 INTERNETWORK SERVICE AND PROTOCOL SPECIFICATION	PARTIAL
5.6.1 INTRODUCTION	N/A
5.6.2 ATN SPECIFIC FEATURES	PARTIAL
5.6.2.1 Purpose of ATN Specific Features	N/A
5.6.2.2 The Security Function	yes
5.6.2.3 Management of Network Priority	N/A
5.6.2.4 Congestion Management	no
5.6.3 ATN SPECIFIC REQUIREMENTS FOR ISO/IEC 8473	PARTIAL
5.6.3.1 Segmentation Function.	yes
5.6.3.2 Security Function	yes
5.6.3.3 Echo Request Function	no
5.6.3.4 Network Priority	N/A
5.6.4 APRLs	N/A
5.7 SPECIFICATION OF SUBNETWORK DEPENDANT CONVERGENCE FUNCTIONS	PARTIAL
5.7.1 INTRODUCTION	N/A
5.7.2 SERVICE PROVIDED BY THE SND CF	YES
5.7.3 SND CF FOR ISO/IEC 8802-2 BROADCAST SUBNETWORKS	YES
5.7.4 SND CF FOR THE COMMON ICAO DATA INTERCHANGE NETWORK (CIDIN)	NO
5.7.5 SND CF FOR ISO/IEC 8208 GENERAL TOPOLOGY SUBNETWORKS	YES
5.7.6 SND CF FOR ISO/IEC 8208 MOBILE SUBNETWORKS	PARTIAL
5.7.6.1 General	yes
5.7.6.2 Call Setup	yes except M/I bit
5.7.6.3 Local Reference Compression Procedures	no
5.7.6.4 ATN NSAP Compression Algorithm (ACA)	no
5.7.7 ATN SND CF PROTOCOL REQUIREMENTS LIST	N/A
5.8 ROUTING INFORMATION EXCHANGE SPECIFICATION	PARTIAL
5.8.1 INTRODUCTION	YES
5.8.2 END SYSTEM TO INTERMEDIATE SYSTEM ROUTING INFORMATION EXCHANGE	YES

PROTOCOL (ES-IS) OVER MOBILE SUBNETWORKS	
5.8.3 INTERMEDIATE SYSTEM TO INTERMEDIATE SYSTEM INTER-DOMAIN ROUTING INFORMATION EXCHANGE PROTOCOL	PARTIAL
<i>5.8.3.1 General</i>	<i>yes</i>
<i>5.8.3.2 ATN Specific Features</i>	<i>partial</i>
5.8.3.2.1 Purpose of ATN Specific Features	N/A
5.8.3.2.2 Use of the Security Path Attribute	yes
5.8.3.2.3 Encoding of the Security Path Attribute Security Information Field	partial
5.8.3.2.4 Update of Security Information	partial
5.8.3.2.5 Route Selection	yes
5.8.3.2.6 Route Aggregation and Route Information Reduction	no
5.8.3.2.7 Frequency of Route Advertisement	no
5.8.3.2.8 Interpretation of Route Capacity	no
5.8.3.2.9 Network Layer Reachability Information	yes
5.8.3.2.10 BISPDU Authentication	yes
5.8.3.2.11 Restrictions on Route Advertisement	yes
5.8.3.2.12 RIB Att Support	yes
5.8.3.2.13 Additional Update PDU Error Handling	no
5.8.3.2.14 CLNP Data PDU Parameters	no
<i>5.8.3.3 Compliance with ISO/IEC 10747</i>	<i>yes</i>
<i>5.8.3.4 APRLs</i>	<i>N/A</i>
5.9 SYSTEMS MANAGEMENT PROVISIONS	N/A

Annex 3: Raised issues - Recommendations

1) Intra-domain routing:

No particular issue has been raised on that subject.

It must however be noted that the intra-domain routing of inter-domain traffic is a particular aspect of the ATN communication which is not covered by the SARPS: Although it is understood that the intra-domain routing mechanisms do not need to be standardised and is under the responsibility of the local administration, it is believed necessary, while keeping the subject outside the scope of the ATN SARPS, that the ATN Guidance material include a description of the problems set by the transit of inter-domain traffic through a Routing Domain, and the possible solutions (e.g. NPDU encapsulation).

2) Inter-domain Ground/Ground Routing:

a) It should possibly be written in the ATN SARPS, or in the ATN Guidance Material, that the use of the ES-IS request redirect function should be precluded in BIS for operation over subnetworks used to connect several Routing Domain.

b) AVO_303 as it is defined cannot be totally covered because it goes beyond the scope of the Package 1 SARPS (Network Management or topology design issue). An explanation could perhaps be written in the GM concerning the best way to ensure the reliability of the ATN service in case of a subnetwork failure (either by Network Management or by defining an adequate topology). Network Management issues should be taken into account in CNS/ATM-2 Package Internet SARPS.

3) Inter-domain Air/Ground Routing:

a) Air/Ground Route Termination procedure:

The following Defect Reports and associated Change Proposal concerning the Air/Ground Route termination procedure have been submitted to WG2:

1. When IDRP is used over an Air-Ground Subnetwork and when no watchdog timer is applied to the subnetwork connection, it is recommended that the Holding Time field in the ISH PDU be set to 65534 seconds so that to allow the suppression of the periodic ISH exchange and to avoid a premature removal from the FIB of the ISH information at expiration of the Holding Timer.
The only action specified by the Air-Ground Route Termination procedure, in section 5.3.5.2.13, when an ISSME receives a leave event, is the invocation of the IDRP deactivate to terminate the BIS-BIS connection. It may be therefore observed, when subnetwork connectivity with a remote ATN router over a mobile subnetwork ceases to be available, that the BIS-BIS connection is closed, that routes are withdrawn from the FIB, but that the ISH information remains stored in the FIB. As a consequence, the network entity of the BIS continues to believe that the remote BIS is reachable via a mobile subnetwork which is nevertheless unavailable. Then in the case where the remote BIS becomes reachable again via another type of subnetwork, the network entity, after the successful exchange of ISH over the new available subnetwork, will think that the remote ATN BIS is reachable via 2 different subnetworks: the old one (which is in fact not available) and the new one. In the same time, the ISSME will perform an IDRP activate action and IDRP will request the network service to convey the OPEN BISPDU to the remote ATN BIS. It may then happen that the network entity attempts to issue the NPDU conveying the OPEN BISPDU, not through the new available subnetwork but through the old unavailable subnetwork. This may prevent the BIS-BIS connection establishment.
2. The Air-Ground Route Termination procedure in section 5.3.5.2.13 provides no directive for the case where the subnetwork connectivity with a remote ATN Router ceases to be available over a mobile subnetwork but remains available over another mobile subnetwork.
It should be said that no IDRP deactivate action must be invoked but that the security attribute of the route must be updated and that the IDRP Routing Decision function must be reinvoked.

Annex 4: Example of a detailed results analysis document: AVE_307

Result of Validation Exercise AVE_307: Shortest path update with IDRP

1. Introduction

AVE_307	AVO_201, AVO_204, AVO_205, AVO_206, AVO_230, AVO_240, AVO_241, AVO_242, AVO_243	AVC_116
---------	---	---------

2. Specification of the exercise

This exercise has been derived from the following documents, written in the frame of the Harmonization Studies of the EURATN project:
 « High-level Specifications of CNS/ATM-1 Package Internet SARPs Validation Exercises - Parts 1, 2 and 3 », SOF_4.0_WD_02
 « Detailed specifications of CNS/ATM- 1 Package Internet SARPS Validation Exercises », SOF_4.0_WD_05

3. Experimental Conditions

This test has been conducted on the EURATN demonstrator with EURATN Version 2.0 Software in Toulouse CENA.

3.1 Experimental Configuration

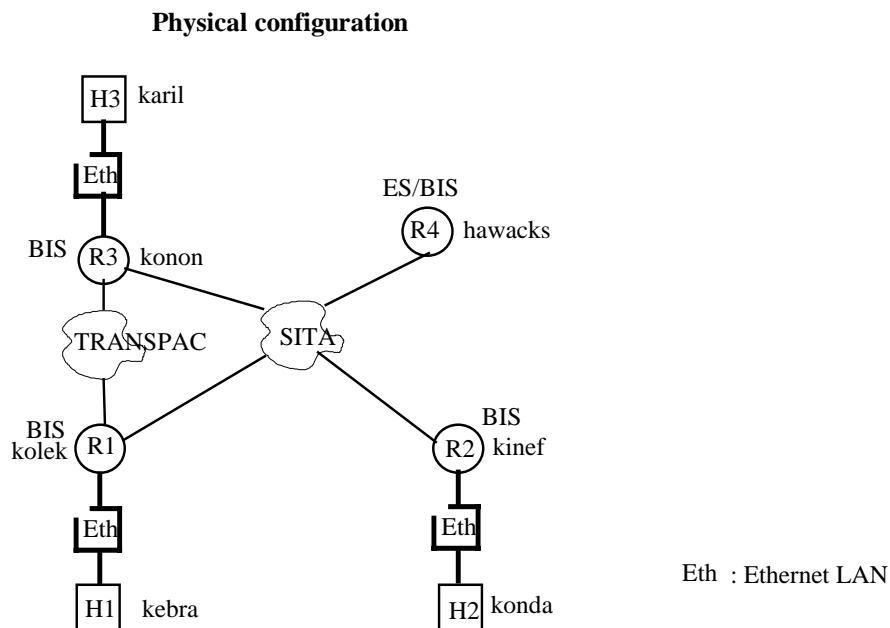

Routing configuration

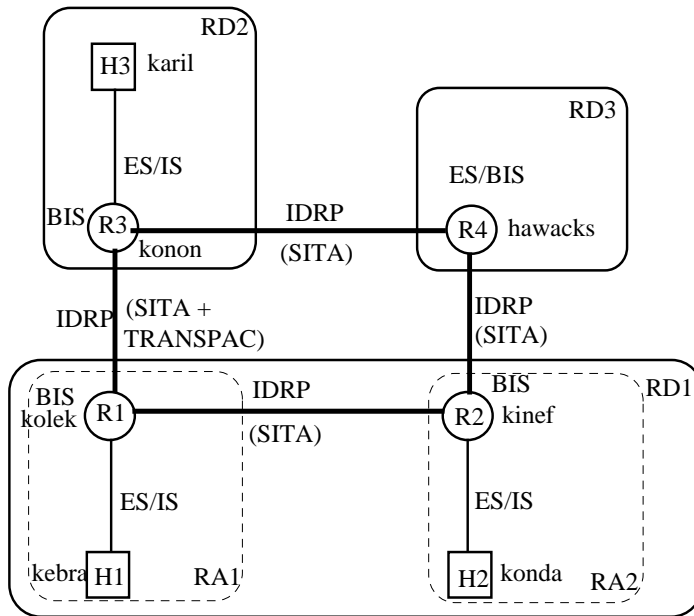

The six workstations are located at CENA Toulouse, using the following addresses:

Workstation	NETs	NSAPs	SNPAs
kolek (R1)	4700270156414c00323232000100000001000100	4700270156414c00323232000100000001000100	Ethernet: 08002019f49b SITA: 233172722f TRANSPAC: 13108059212f
kebra (H1)	4700270156414c00323232000100000003000200	4700270156414c00323232000100000003000201	Ethernet: 0800200d96af
kinef (R2)	4700270156414c00323232000200000001000500	4700270156414c00323232000200000001000500	Ethernet: 08002019f151 SITA: 233172724f
konda (H2)	4700270156414c00323232000200000003000600	4700270156414c00323232000200000003000601	Ethernet: 08002019f0b6
konon (R3)	4700270156414c00313131000000000001000300	4700270156414c00313131000000000001000300	Ethernet: 08002019f70f SITA: 233172723f TRANSPAC: 13108059213f
karil (H3)	4700270156414c00313131000000000003000400	4700270156414c00313131000000000003000401	Ethernet: 08002019f0b4
hawacks (R4)	4700270156414c00333333000000000001000700	4700270156414c00333333000000000001000700 4700270156414c00333333000000000001000701	SITA: 2331807f

Neighbor ISs:

- kolek is declared as neighbor of kinef on the SITA X.25 Subnetwork.
- kolek is declared as neighbor of konon on the SITA and TRANSPAC X.25 Subnetworks.
- konon is declared as neighbor of hawacks on the SITA X.25 Subnetwork.
- kinef is declared as neighbor of hawacks on the SITA X.25 Subnetwork.

IDRP Specific:

- konon is declared as adjacent BIS of kolek.
- kinef is declared as adjacent BIS of kolek
- konon is declared as adjacent BIS of hawacks
- kinef is declared as adjacent BIS of hawacks

Intra-domain Specific:

- kolek is declared as intra-domain Next-Hop IS from kinef to access RA1 of RD1
- kinef is declared as intra-domain Next-Hop IS from kolek to access RA2 of RD1

TSTG Scenario:

The TSTG scenario used for this test on kebra to communicate with konda is the following: On a COTP, Send 40 data units of 100 bytes each, every 8 seconds .

The TSTG scenario used for this test on konda to communicate with karil is the following: On a COTP, Send 30 data units of 100 bytes each, every 3 seconds .

3.2 Specific ATN conditions

See EURATN PICS

4. Collection of STEP1 results

4.1 Test report

The STEP 1 exercise lasted 10 minutes.

From the traces of the CLNP protocols on R1 and R4, the history of the test has been summarized in the table below:

Event/ phase number	Event/phase description
1.	The BIS-BIS connection between R1 and R2 is established: R1 sends to R2 an OPEN BISPDU which is acknowledged by the sending of an OPEN BISPDU from R2 to R1.
2.	The BIS-BIS connection between R2 and R4 is established: R4 sends to R2 an OPEN BISPDU which is acknowledged by the sending of an OPEN BISPDU from R2 to R4.
3.	R2 sends to R4 via Sita an UPDATE BISPDU advertising the route to RD2
4.	The FIB of R4 is updated with the route to RD2 via R2
5.	R4 sends to R2 via Sita an UPDATE BISPDU advertising the route to RD3
6.	The FIB of R2 is updated with the route to RD3 via R4
7.	R2 sends to R1 via Sita an UPDATE BISPDU with a local preference of 254 and advertising the route to RD3
8.	The FIB of R1 is updated with the route to RD3 via R2
9.	The BIS-BIS connection between R1 and R3 is established
10.	R3 sends to R1 via Transpac an UPDATE BISPDU advertising the route to RD1
11.	The FIB of R1 is updated with the route to RD1 via R3
12.	R1 sends to R3 via Sita an UPDATE BISPDU advertising the route to RD2
13.	R1 sends to R3 via Transpac an UPDATE BISPDU advertising the route to RD3
14.	The FIB of R3 is updated with the routes to RD2 and RD3 via R1
15.	R1 sends to R2 via Sita an UPDATE BISPDU with a local preference of 254 and advertising the route to RD1
16.	The FIB of R2 is updated with the route to RD1 via R1
17.	The BIS-BIS connection between R3 and R4 is established
18.	R2 sends to R4 via Sita an UPDATE BISPDU advertising the route to RD1
19.	R3 sends to R4 via Sita an UPDATE BISPDU advertising the route to RD1
20.	R3 sends to R4 via Sita an UPDATE BISPDU advertising the route to RD2
21.	The FIB of R4 is updated with the route to RD1 via R3
22.	R4 sends to R3 via Sita an UPDATE BISPDU advertising the route to RD3
23.	R4 sends to R3 via Sita an UPDATE BISPDU advertising the route to RD2
24.	In the FIB of R3, the route to RD3 via R1 is replaced by the route to RD3 via R4
25.	R4 sends to R2 via Sita an UPDATE BISPDU advertising the route to RD1
26.	R2 sends to R1 via Sita an UPDATE BISPDU with a local preference of 253 and advertising the route to RD1 via R4
27.	R3 sends to R1 via Sita an UPDATE BISPDU advertising the route to RD3
28.	R1 sends to R2 via Sita an UPDATE BISPDU with a local preference of 253 and advertising the route to RD3 via R3
29.	<p>The routing is then stable. Only KEEPALIVE BISPDU are then exchanged between the BISs on the 4 BIS-BIS connections. The FIBs are not modified any more and stay in the following state:</p> <p>the FIB of R1 includes:</p> <ul style="list-style-type: none"> • RD1 reachable via R3 • RD3 reachable via R2 <p>the FIB of R2 includes:</p> <ul style="list-style-type: none"> • RD1 reachable via R1 • RD3 reachable via R4 <p>the FIB of R3 includes:</p> <ul style="list-style-type: none"> • RD2 reachable via R1 • RD3 reachable via R3 <p>the FIB of R4 includes:</p> <ul style="list-style-type: none"> • RD1 reachable via R3 • RD2 reachable via R2

30.	Transport Service Traffic Generators are started on H1 and H2 and the generation of a connection-oriented traffic using one single transport connection and issuing 40 messages of 100 bytes at the frequency of one every 8 seconds, is requested from H1 to H2 with echo of every message received by H2 back to H1.
31.	H1 sends a CR TPDU. The PDU is issued on the Ethernet LAN to R1, forwarded by R1 toward R2 via SITA, forwarded by R2 toward H2 via the Ethernet LAN, and received by H2.
32.	H2 answers to CR by a CC TPDU which is issued on the LAN toward R2, forwarded by R2 toward R1 via Sita, and then forwarded by R1 to H1 via the Ethernet LAN.
33.	On receipt of the CC TPDU, H1 sends an AK TPDU. The PDU follows the path H1-R1-R2-H2
34.	Every 8 seconds, H1 sends a DT TPDU. the packets follow the path H1-R1-R2-H2. Every DT packet received by H2 is sent back to H1 via R2 and R1. AK TPDU's are generally sent concatenated with DT TPDU's.
35.	A Transport Service Traffic Generator is started on H3 and the generation of a connection-oriented traffic using one single transport connection and issuing 30 messages of 100 bytes at the frequency of one every 3 seconds, is requested from H2 to H3 with echo of every message received by H3 back to H2.
36.	H2 sends a CR TPDU. The PDU is issued on the Ethernet LAN to R2, forwarded by R2 toward R1 via SITA, forwarded by R1 toward R3 via Transpac, forwarded by R3 toward H3 via the Ethernet LAN, and received by H3.
37.	H3 answers to CR by a CC TPDU which is issued on the LAN toward R3, forwarded by R3 toward R1 via Sita, forwarded by R1 toward R2 via Sita and then forwarded by R2 to H2 via the Ethernet LAN.
38.	On receipt of the CC TPDU, H2 sends an AK TPDU. The PDU follows the path H2-R2-R1-R3-H3
39.	Every 3 seconds, H2 sends a DT TPDU. the packets follow the path H2-R2-R1-Sita or Transpac-R3-H3. Every DT packet received by H2 is sent back to H1 following the reverse path. AK TPDU's are generally sent concatenated with DT TPDU's. It is observed that each time R1 receives from R3 on Sita, an NPDU which needs to be forwarded to R2, then R1 forwards correctly the NPDU but issues additionally to R3 a Redirect PDU indicating that the NPDU can directly be forwarded by R3 to R2 via Sita. In the same way, each time R1 receives from R2 on Sita, an NPDU which needs to be forwarded to R3, then R1 forwards correctly the NPDU but issues additionally to R2 a Redirect PDU indicating that the NPDU can directly be forwarded by R2 to R3 via Sita
40.	50 seconds after the 30st DT TPDU was issued, H2 closes the Transport connection by issuing a DR TPDU.
41.	The DR TPDU is received by H3 and confirmed with a DC TPDU which is sent by H3 back to H2.
42.	The Transport Service Traffic Generator on H1 reports that the Transport connection has been closed normally and that no data has been lost during the test.
43.	While data continues to be exchanged between H1 and H2, R4 is stopped. CEASE BISPDU's are sent by R4 to R2 and R3
44.	R3 sends to R1 an UPDATE BISPDU withdrawing the route to RD3.
45.	R2 sends to R1 an UPDATE BISPDU withdrawing the route to RD3
46.	R2 sends to R1 an UPDATE BISPDU withdrawing the route to RD1 via R4
47.	The route to RD3 is removed from the FIBs of R1 R2 and R3.
48.	While data continues to be exchanged between H1 and H2, R3 is stopped. A CEASE BISPDU is sent by R3 to R1
49.	R1 sends to R2 an UPDATE BISPDU withdrawing the route to RD1
50.	The route to RD1 is removed from the FIBs of R1 and R2.
51.	50 seconds after the 40th DT TPDU was issued, H1 closes the Transport connection by issuing a DR TPDU.
52.	The DR TPDU is received by H2 and confirmed with a DC TPDU which is sent by H2 back to H1.
53.	The Transport Service Traffic Generator on H2 reports that the Transport connection has been closed normally and that no data has been lost during the test.

4.2 Test analysis

The main objectives of the test were met:

- the external and internal BIS-BIS connections were successfully established.
- the BIS-BIS connections have remained alive for the duration of the test
- the FIBs of R1, R2 and R3 were correctly updated. All BIS chose the best routes.
- the end-to-end communications between H1 and H2 and between H2 and H3 were verified

The detailed analysis of the events allows to put forward the role played by the different involved ATN and OSI functions:

- Events 1 and 2 are the result of the IDRPs activate action on R1, R2 and R4. Each BIS, tries to establish an IDRPs connection with its configured neighbors by sending periodically OPEN BISPDU's. A bi-directional exchange of OPEN BISPDU's leads to have the BIS-BIS connections set in the established state.
- Events 3 and 5 correspond to the route advertisement sequence and leads to the update of the FIB of each router (addition of routes learned from the adjacent router(events 4 and 6))
- Event 7 is the result of the IDRPs internal update function which is concerned with the distribution of routing information to BISs located in the local BIS's own routing Domain. It is observed that the route to RD3 is correctly advertised by R2 to all BISs located in RD1 (i.e. to R1). It is verified that the UPDATE BISPDU generated as a result of the IDRPs internal update function conveys the local preference computed by the R2 for the route. The value of the local preference of the route to RD3 is 254; this corresponds to what was expected considering that the local policy configured in R2 for the computation of the local preference is: result of « 255 minus the number of hops between RD1 and the destination RD of the route ». R1 stores this route in its FIB (event 8).
- R3 is then started and the BIS-BIS connection between R1 and R3 is successfully established (event 9).
- Events 10, and 12 correspond to the route advertisement sequence between R1 and R3: each BIS advertises the route to its own routing domain.
- Event 13 confirms that RD2 plays correctly its role of Transit Routing Domain and propagates routes learned from adjacent Routing Domains to the other routing Domain.
- As a consequence of these route advertisement sequences, it is verified under steps 11 and 14 that routes learned from the adjacent BIS are correctly stored in the FIB of the routers.
- Event 15 is the result of the IDRPs internal update function which is concerned with the distribution of the routing information to BISs located in the local BIS's own routing Domain. It is observed that the route to RD1 is correctly advertised by R1 to all BISs located in RD1 (i.e. to R2). It is verified that the UPDATE BISPDU generated as a result of the IDRPs internal update function conveys the local preference computed by the R1 for the route. The value of the local preference of the route to RD1 is 254; this corresponds to what was expected considering that the local policy configured in R1 for the computation of the local preference is: result of « 255 minus the number of hops between RD1 and the destination RD of the route ». R2 stores this route in its FIB (event 16).
- The BIS-BIS connection between R3 and R4 is then established (event 17). This closes the routing loop constituted by the full inter-connection of the 3 Routing Domains.
- Event 18 is the continuation of the propagation of the route to RD1 by RD2 routers. After the internal update phase (event 16 above), the RD2 routers enter the external update phase, and R2 advertises consequently to its external adjacent BIS the routes learned from its other adjacent BISs. Thanks to this, the route to RD1 has been propagated through RD2 to R3 and it is verified that RD1 fulfills its Transit Routing Domain function.
- Events 19, 20, 22 and 23 correspond to the route advertisement sequence between R4 and R3: each BIS advertises the best known routes.
- Event 21 shows the result of the IDRPs route selection function in R4, occurring just after the quasi-simultaneous receipt of 2 different routes to RD1 (events 18 and 19). It must be noted that R4 only selects one route (the direct route to RD1 via R3 as expected) and update the FIB accordingly.
- Event 24 is another example of the IDRPs route selection function: R3 detects that the new route to RD3 received in step 22, is better than the previously known route to RD3 via R1. It then chooses to replace in the FIB the old route by the new one.
- Event 25 is the logical consequence of event 21: the route to RD1 known by R4 is considered by R4 as the best route to RD1, and R4 knows that, although R2 already knows one route to RD1, R2 does not know this best route. R4 asks therefore R2 to consider this new route to RD1 by advertising it in an UPDATE BISPDU.

Note that R4 does not advertise the route to RD1 via R2 to R3. There are 2 reasons for this: first a BIS only advertises its best routes (and the route to RD1 via R2 is not the best route); secondly a BIS must not advertise a route to a BIS of a RD being included in the RD path of the route (and RD1 is necessarily in the path of the route to RD1).

- Event 26 is also of interest: it shows the difference existing between the propagation of route to adjacent internal BIS compared to the propagation of route to adjacent external BIS: only the best routes are propagated to external BISs (this is the result of the external update (phase 3) IDR process which only occurs after the route selection (phase 2) IDR process); on the other hand, all routes (the best and the others) to external RD are propagated to internal BISs (this is the result of the internal update (phase 1) IDR process which takes place before the route selection (phase 2) IDR process). According to this, R2 propagates the new route to RD1 (via R3) to R1, even if it is not the preferred route, as shown by the value of local preference of this new route (it is set to 253 whereas the old route to RD1 has the local preference 254 (see event 15))

It must be noted that this new route to RD1 does not replace the old direct route to RD1: this is because the route selection IDR process sees that the new route has less preference as the old route.

- Events 27 and 28 are equivalent to the event 25 and 26 but concern the propagation of the new route to RD3.
- Phase 29 consists of the periodic exchange of KEEPALIVE BISPDU which is typical of a BIS-BIS connection in the established state when routing is stable. The content of the FIBs is the expected one.
- On Step 30 the traffic generation scenario between H1 and H2 is started.
- Events 31, 32 and 33 constitute the TPDUs exchange sequence leading to the establishment of the transport connection between H1 and H3.
- Phase 34 consists of the exchange of DT TPDUs corresponding to the traffic between H1 and H2 parametrized for the test on the Transport Service Traffic Generator. The PDUs are correctly routed between H1 and H2, via R1 and R2.
- On Step 35 the traffic generation scenario between H2 and H3 is started
- Events 36, 37 and 38 constitute the TPDUs exchange sequence leading to the establishment of the transport connection between H2 and H3.
- Phase 39 consists of the exchange of DT TPDUs corresponding to the traffic between H2 and H3 parametrized for the test on the Transport Service Traffic Generator. The PDUs are correctly routed between H2 and H3, via R2, R1 and R3. This new data traffic does not put burden on the traffic simultaneously generated between H1 and H2.

The issuing of Redirect PDUs results of the triggering of the ES-IS Request Redirect function in R1. This function analyses the decision made by the forwarding process and determine if the previous BIS (R3 or R2) could have sent the NPDU directly to the Network entity R1 is about to forward the PDU to. Each time a PDU is received by R1 on Sita, this request redirect function is triggered since there is a shortest path, direct between R2 and R3 via Sita. Note that both R2 and R3 does not take into account the Redirect PDUs, and never bypass R1: this is because it is considered in the EURATN implementation that the redirect information is only relevant for intra-domain routing and must not take precedence to the inter-domain routing information.

- Events 40 and 41 result of the release, by the tool, of the Transport Connection, at the end of the configured test.
- Events 42 confirms the success of the tests. The transport connection was successfully established, and was cleared normally after all data have successfully been transmitted.
- Event 43 is the release of the BIS-BIS connections existing between R4 and R2 and between R4 and R3. This is the consequence of the operator request to stop R4.
- The stop of R4 means for the other BISs that RD3 is no more reachable, and that RD3 cannot serve as a transit RD anymore to destination in RD1 or RD2. Some routes previously advertised becomes therefore unfeasible and this is signaled by the BISs by the sending of UPDATE BISPDU withdrawing the unfeasible routes (events 44, 45 and 46). The FIBs are updated accordingly (event 47).
- Event 48 is equivalent to event 43, but is the result of the stop of R3.
- Events 49 and 50 are of the same nature as events 44, 45, 46, and 47.
- Events 51 and 52 result of the release, by the tool, of the Transport Connection between H1 and H2, at the end of the configured test.
- Events 53 confirms the success of the test. The transport connection was successfully established, and was cleared normally after all data have successfully been transmitted.

4.3 Relation to the expected results

<i>Expected result (as documented in SOF_4.0_WD_05)</i>	Result check report
<i>Each routing domain must discover dynamically his neighbour routing domain.</i>	OK
<i>The FIB traces file shall contain :</i>	
<i>Intermediate system R1 :</i>	
<i>The ES neighbour part must contain both NSAP and SNPA addresses of H1.</i>	OK
<i>The IS neighbour part must contain :</i>	
<i>NSAP and SNPA addresses of R2 through the WAN2 subnetwork.</i>	OK
<i>NSAP and SNPA addresses of R3 through the WAN1 and WAN2 subnetworks.</i>	OK
<i>The Intra-Domain part must contain an entry to reach RA2 through R2.</i>	OK
<i>The Inter-Domain part must contain :</i>	
<i>An entry to reach RD1 through R3.</i>	OK
<i>An entry to reach RD4 through R2. or R3</i>	OK
<i>Intermediate system R2 :</i>	
<i>The ES neighbour part must contain both NSAP and SNPA addresses of H2.</i>	OK
<i>The IS neighbour part must contain :</i>	
<i>NSAP and SNPA addresses of R1 through the WAN2 subnetwork.</i>	OK
<i>NSAP and SNPA addresses of R4 through the WAN2 subnetwork.</i>	OK
<i>The Intra-Domain part must contain an entry to reach RA1 through R1.</i>	OK
<i>The Inter-Domain part must contain :</i>	
<i>An entry to reach RD3 through R4.</i>	OK
<i>An entry to reach RD1 through R1 or R4.</i>	OK
<i>Intermediate system R3 :</i>	
<i>The ES neighbour part must contain both NSAP and SNPA addresses of H3.</i>	OK
<i>The IS neighbour part must contain :</i>	
<i>NSAP and SNPA addresses of R1 through the WAN1 and WAN2 subnetworks.</i>	OK
<i>NSAP and SNPA addresses of R4 through the WAN2 subnetwork.</i>	OK
<i>The Inter-Domain part must contain :</i>	
<i>An entry to reach RD3 through R4.</i>	OK
<i>An entry to reach RD2 through R1</i>	OK
<i>Intermediate system R4 :</i>	
<i>The ES neighbour part must contain both NSAP and SNPA addresses of H4.</i>	OK
<i>The IS neighbour part must contain :</i>	
<i>NSAP and SNPA addresses of R2 through the WAN2 subnetwork.</i>	OK

<i>NSAP and SNPA addresses of R3 through the WAN2 subnetwork.</i>	<i>OK</i>
<i>The Inter-Domain part must contain :</i>	
<i>An entry to reach RD1 through R3.</i>	<i>OK</i>
<i>An entry to reach RD2 through R2.</i>	<i>OK</i>
<i>End System H1 must be able to establish a reliable transport connection with H2 through the WAN2 subnetwork between R1 and R2.</i>	<i>OK</i>
<i>The CLNP traces file on R1 shall contain :</i>	
<i>When receiving NPDU coming from H1 to H2, Intermediate System R1 must send this NPDU directly to R2 through WAN2.</i>	<i>OK</i>
<i>The CLNP traces file on R2 shall contain :</i>	
<i>When receiving NPDU coming from H2 to H1, Intermediate System R2 must send this NPDU directly to R1 through WAN2.</i>	<i>OK</i>
<i>The report scenario file on H1 shall contain :</i>	
<i>The report generated by the TSTG in H1 shall state that no TPDU has been lost</i>	<i>OK</i>
<i>End System H2 must be able to establish a reliable transport connection with H3.</i>	<i>OK</i>
<i>The CLNP traces file on R3 shall contain :</i>	
<i>When receiving an NPDU coming from H3 for H2, Intermediate System R3 must send this NPDU to R2 via R1.</i>	<i>OK</i>
<i>The CLNP traces file on R2 shall contain :</i>	
<i>When receiving an NPDU coming from H2 to H3, Intermediate System R2 must send this NPDU to R3 via R1.</i>	<i>OK</i>
<i>The report scenario file on H2 shall contain :</i>	
<i>The report generated by the TSTG in H2 shall state that no TPDU has been lost</i>	<i>OK</i>

4.4 Raised issues

No new issue has been raised

5. Collection of STEP2 results

5.1 Test report

The STEP 1 exercise lasted 10 minutes.

From the traces of the CLNP protocols on R1 and R4, the history of the test has been summarized in the table below:

Event/ phase number	Event/phase description
1.	The BIS-BIS connection between R1 and R2 is established: R1 sends to R2 an OPEN BISPDU which is acknowledged by the sending of an OPEN BISPDU from R2 to R1.
2.	The BIS-BIS connection between R2 and R4 is established: R4 sends to R2 an OPEN BISPDU which is acknowledged by the sending of an OPEN BISPDU from R2 to R4.

3.	R4 sends to R2 via Sita an UPDATE BISPDU advertising the route to RD3
4.	The FIB of R2 is updated with the route to RD3 via R4
5.	R2 sends to R4 via Sita an UPDATE BISPDU advertising the route to RD2
6.	The FIB of R4 is updated with the route to RD2 via R2
7.	R2 sends to R1 via Sita an UPDATE BISPDU with a local preference of 254 and advertising the route to RD3
8.	The FIB of R1 is updated with the route to RD3 via R2
9.	The BIS-BIS connection between R1 and R3 is established
10.	R3 sends to R1 via Transpac an UPDATE BISPDU advertising the route to RD1
11.	The FIB of R1 is updated with the route to RD1 via R3
12.	R1 sends to R2 via Sita an UPDATE BISPDU with a local preference of 254 and advertising the route to RD1
13.	The FIB of R2 is updated with the route to RD1 via R1
14.	R1 sends to R3 via Sita an UPDATE BISPDU advertising the route to RD2
15.	R1 sends to R3 via Transpac an UPDATE BISPDU advertising the route to RD3
16.	The FIB of R3 is updated with the routes to RD2 and RD3 via R1
17.	The BIS-BIS connection between R3 and R4 is established
18.	R2 sends to R4 via Sita an UPDATE BISPDU advertising the route to RD1
19.	R4 sends to R3 via Sita an UPDATE BISPDU advertising the route to RD3
20.	R4 sends to R3 via Sita an UPDATE BISPDU advertising the route to RD2
21.	In the FIB of R3, the route to RD3 via R1 is replaced by the route to RD3 via R4
22.	R3 sends to R4 via Sita an UPDATE BISPDU advertising the route to RD1
23.	R3 sends to R4 via Sita an UPDATE BISPDU advertising the route to RD2
24.	The FIB of R4 is updated with the route to RD1 via R3
25.	R4 sends to R2 via Sita an UPDATE BISPDU advertising the route to RD1
26.	R3 sends to R1 via Sita an UPDATE BISPDU advertising the route to RD3
27.	R1 sends to R2 via Sita an UPDATE BISPDU with a local preference of 253 and advertising the route to RD3 via R3
28.	R2 sends to R1 via Sita an UPDATE BISPDU with a local preference of 253 and advertising the route to RD1 via R4
29.	<p>The routing is then stable. Only KEEPALIVE BISPDU's are then exchanged between the BISs on the 4 BIS-BIS connections. The FIBs are not modified any more and stay in the following state:</p> <p>the FIB of R1 includes:</p> <ul style="list-style-type: none"> • RD1 reachable via R3 • RD3 reachable via R2 <p>the FIB of R2 includes:</p> <ul style="list-style-type: none"> • RD1 reachable via R1 • RD3 reachable via R4 <p>the FIB of R3 includes:</p> <ul style="list-style-type: none"> • RD2 reachable via R1 • RD3 reachable via R3 <p>the FIB of R4 includes:</p> <ul style="list-style-type: none"> • RD1 reachable via R3 • RD2 reachable via R2
30.	A Transport Service Traffic Generator is started on H2 and the generation of a connection-oriented traffic using one single transport connection and issuing 30 messages of 100 bytes at the frequency of one every 3 seconds, is requested from H2 to H3 with echo of every message received by H3 back to H2.
31.	H2 sends a CR TPDU. The PDU is issued on the Ethernet LAN to R2, forwarded by R2 toward R1 via SITA, forwarded by R1 toward R3 via Transpac, forwarded by R3 toward H3 via the Ethernet LAN, and received by H3.
32.	The Transport Service Traffic Generator was not started on H3. The transport protocol on H3 refuses the connection request by issuing a DR TPDU back to H2. The DR TPDU is issued on the LAN toward R3, forwarded by R3 toward R1 via Sita, forwarded by R1 toward R2 via Sita and then forwarded by R2 to H2 via the Ethernet LAN.

33.	On receipt of the DR by H2, a T-Disconnect-indication is received by the Transport Service Traffic Generator of H2. The tool reports that the test is prematurely stopped and that no data has been exchanged.
34.	A Transport Service Traffic Generator is started on H3 and the generation of a connection-oriented traffic using one single transport connection and issuing 30 messages of 100 bytes at the frequency of one every 3 seconds, is requested again from H2 to H3 with echo of every message received by H3 back to H2.
35.	H2 sends a CR TPDU. The PDU is issued on the Ethernet LAN to R2, forwarded by R2 toward R1 via SITA, forwarded by R1 toward R3 via Transpac, forwarded by R3 toward H3 via the Ethernet LAN, and received by H3.
36.	H3 answers to CR by a CC TPDU which is issued on the LAN toward R3, forwarded by R3 toward R1 via Sita, forwarded by R1 toward R2 via Sita and then forwarded by R2 to H2 via the Ethernet LAN.
37.	On receipt of the CC TPDU, H2 sends an AK TPDU. The PDU follows the path H2-R2-R1-R3-H3
38.	Every 3 seconds, H2 sends a DT TPDU. the packets follow the path H2-R2-R1-Sita or Transpac-R3-H3. Every DT packet received by H2 is sent back to H1 following the reverse path. AK TPDUs are generally sent concatenated with DT TPDUs. It is observed that each time R1 receives from R3 on Sita, an NPDU which needs to be forwarded to R2, then R1 forwards correctly the NPDU but issues additionally to R3 a Redirect PDU indicating that the NPDU can directly be forwarded by R3 to R2 via Sita. In the same way, each time R1 receives from R2 on Sita, an NPDU which needs to be forwarded to R3, then R1 forwards correctly the NPDU but issues additionally to R2 a Redirect PDU indicating that the NPDU can directly be forwarded by R2 to R3 via Sita
39.	After some successful exchange of data between H2 and H3, and while data continues to be exchanged, R1 is stopped. CEASE BISPDU are sent by R1 to R2 and R3
40.	In the FIB of R2, the route to RD1 via R1 is replaced by the route to RD1 via R4
41.	In the FIB of R3, the route to RD2 via R1 is replaced by the route to RD2 via R4
42.	R3 sends to R4 an UPDATE BISPDU withdrawing the route to RD2 via R3.
43.	R2 sends to R4 an UPDATE BISPDU withdrawing the route to RD1 via R2
44.	It is then observed that the TPDUs issued by H2 toward H3 go through the path H2-R2-R4-R3-H3 and that the TPDUs issued by H3 toward H2 go through the path H3-R3-R4-R2-H2 It is noted that a few number of DT TPDUs are retransmitted by the transport entities of H2 and H3
45.	50 seconds after the 30st DT TPDU was issued, H2 closes the Transport connection by issuing a DR TPDU.
46.	The DR TPDU is received by H3 and confirmed with a DC TPDU which is sent by H3 back to H2.
47.	The Transport Service Traffic Generator on H2 reports that the Transport connection has been closed normally and that no data has been lost during the test.

5.2 Test analysis

The main objectives of the test were met:

- The IDRP protocol on each BIS reacted to the router failure in finding new feasible routes replacing the broken routes
- the transport connection between H2 and H3 was not impacted by the BIS failure and the consequent routing modification

The detailed analysis of the events allows to put forward the role played by the different involved ATN and OSI functions:

- Events 1 to 29 are equivalent, although being in a different order, to events 1 to 29 of STEP 1.
- Events 30, 31, 32 and 33 are due to an error of the operator: he forgot to start the Traffic Generator on H3. As there was no application registered on the addressed TSAP on H3, the transport protocol logically rejected the call request from H2.
- On Step 34 the traffic generator is launched on H3 and the test scenario between H2 and H3 is restarted

- Events 35, 36, and 37 constitute the TPDU exchange sequence leading to the establishment of the transport connection between H2 and H3.
- Phase 38 consists of the exchange of DT TPDU corresponding to the traffic between H2 and H3 parametrized for the test on the Transport Service Traffic Generator. The PDUs are correctly routed between H2 and H3, via R2, R1 and R3.

The issuing of Redirect PDUs results of the triggering of the ES-IS Request Redirect function in R1. This function analyses the decision made by the forwarding process and determine if the previous BIS (R3 or R2) could have sent the NPDU directly to the Network entity R1 is about to forward the PDU to. Each time a PDU is received by R1 on Sita, this request redirect function is triggered since there is a shortest path, direct between R2 and R3 via Sita. Note that both R2 and R3 does not take into account the Redirect PDUs, and never bypass R1: this is because it is considered in the EURATN implementation that the redirect information is only relevant for intra-domain routing and must not take precedence to the inter-domain routing information.

- Event 39 is the release of the BIS-BIS connections existing between R1 and R2 and between R1 and R3. This is the consequence of the operator request to stop R1.
- The stop of R1 means for the other BISs that all known routes going through R1 become unfeasible. The FIBs are updated accordingly (events 40 and 41) and the loss of the routes is propagated to the adjacent BISs when required (events 42 and 43).
- In phase 43, the effect of the dynamic adaptive routing provided by the IDRP protocol is observed. The traffic exchanged between H2 and H3 is rerouted on the feasible path going through R4. The observed TPDU retransmissions can be easily explained by the fact that there was a short period of time between the stop of R1 and the consequent update of FIBs of the other routers, during which the issued TPDU are forwarded to R1; these TPDU are therefore lost and the transport protocols on H2 and H3 plays their role by retransmitting all lost or unacknowledged DT TPDU.
- Events 44 and 45 result of the release, by the tool, of the Transport Connection, at the end of the configured test.
- Events 46 confirms the success of the tests. The transport connection was successfully established, and was cleared normally after all data have successfully been transmitted and this in spite of the simulated failure of R1 which caused the data traffic to be rerouted during the test.

5.3 Relation to the expected results

<i>Expected result (as documented in SOF_4.0_WD_05)</i>	Result check report
<i>Each routing domain must be able to recover dynamically from the R1 shutdown.</i>	OK
<i>The FIB traces file shall contain :</i>	
<i>Intermediate system R2 :</i>	
<i>The ES neighbour part must contain both NSAP and SNPA addresses of H2.</i>	OK
<i>The IS neighbour part must contain :</i>	
<i>NSAP and SNPA addresses of R4 through the WAN2 subnetwork (static definition).</i>	OK
<i>NSAP and SNPA addresses of R1 through the WAN2 subnetwork (static definition).</i>	OK
<i>The Intra-Domain part must contain an entry to reach R1 directly (static definition).</i>	OK
<i>Before R1 is stopped, the Inter-Domain part must contain :</i>	
<i>An entry to reach RD1 through R1.</i>	OK
<i>An entry to reach RD3 through R4.</i>	OK
<i>When R1 is stopped, the Inter-domain part must be updated as follows:</i>	

<i>An entry to reach RD1 through R4.</i>	OK
<i>An entry to reach RD3 through R4.</i>	OK
<u><i>Intermediate system R3 :</i></u>	
<i>The ES neighbour part must contain both NSAP and SNPA addresses of H3.</i>	OK
<i>The IS neighbour part must contain :</i>	
<i>NSAP and SNPA addresses of R1 through the WAN1 and WAN2 subnetworks.</i>	OK
<i>NSAP and SNPA addresses of R4 through the WAN2 subnetwork.</i>	OK
<i>Before R1 is stopped, the Inter-Domain part must contain :</i>	
<i>An entry to reach RD3 through R4.</i>	OK
<i>An entry to reach RD2 through R1.</i>	OK
<i>When R1 is stopped, the Inter-domain part must be updated as follows:</i>	
<i>An entry to reach RD3 through R4.</i>	OK
<i>An entry to reach RD2 through R4.</i>	OK
<u><i>Intermediate system R4 :</i></u>	
<i>The ES neighbour part must contain both NSAP and SNPA addresses of H4.</i>	OK
<i>The IS neighbour part must contain :</i>	
<i>NSAP and SNPA addresses of R2 through the WAN2 subnetwork (static definition).</i>	OK
<i>NSAP and SNPA addresses of R3 through the WAN2 subnetwork.</i>	OK
<i>The Inter-Domain part must contain :</i>	
<i>An entry to reach RD1 through R3.</i>	OK
<i>An entry to reach RD2 through R3.</i>	OK
<i>End System H2 must be able to establish a reliable transport connection with H3 via R1, then R4.</i>	OK
<u><i>The CLNP traces file on R2 shall contain :</i></u>	
<i>When receiving NPDU coming from H2 destined to H3, Intermediate System R2 must send this NPDU to R3 via R1, then via R4 when R1 is stopped.</i>	OK
<u><i>The CLNP traces file on R3 shall contain :</i></u>	
<i>When receiving NPDU coming from H3 destined to H2, Intermediate System R3 must send this NPDU to R2 via R1, then via R4 when R1 is stopped.</i>	OK
<u><i>The COTP traces file on H2 and H3 shall contain :</i></u>	
<i>When R1 is stopped, some TPDU's can be retransmitted before the new path is established.</i>	OK
<u><i>The report scenario file on H2 shall contain :</i></u>	
<i>The report generated by the TSTG in H2 shall state that no TPDU has been lost</i>	OK

5.4 Raised issues

No new issue has been raised

6. Evaluation of the results

6.1 Validated items of the SARPs

This exercise validates some parts of the following sections of the ATN Internet SARPs:

- 5.3.2.2.2 Forwarding a CLNP NPDU when no Security Parameter is present in the PDU Header
- 5.3.3.1 Interconnection of ATN RDs
- 5.3.4 Ground-Ground Interconnection
- 5.4 Network and Transport Addressing Specification
- 5.5.1. Transport Service and Protocol Specification - General
- 5.5.2 Connection Mode Transport Layer Operation
 - Subsections 5.5.2.1, 5.5.2.2, 5.5.2.3, 5.5.2.4.
- 5.6.4 APRLs (for Mandatory APRLs and the specific EURATN implementation options)
- 5.7.3 SNDCF for ISO/IEC 8802-2 Broadcast subnetworks
- 5.7.5.SNDCF for ISO/IEC 8208 subnetworks
 - 5.7.7.2, 5.7.7.3, 5.7.7.4, 5.7.7.5, 5.7.7.6, 5.7.7.7 APRLs for fixed SNDCFs
- 5.8.3.2.9 Network Layer Reachability Information
- 5.8.3.2.10 BISPDU Authentication
- 5.8.3.2.11 Restriction on Routes Advertisement
- 5.8.3.4.3 to 5.8.3.4.15 APRLs for IDRP

6.2 Validation Objectives Coverage

The Validation Objectives that are covered by this exercise are:

AVO_201: « Verify that two compliant ATN End Systems interoperate and provide Connection-Oriented Transport Service to Transport Service users. »

AVO_204: « Verify that two compliant ATN End Systems interoperate and provide the Transport Service across multiple subnetworks »

AVO_205: The following features have been covered : « Connection Establishment, routing update, route advertisement, disconnection ».

AVO_206: The following features have been covered : « Connection Establishment, routing update, route advertisement, disconnection, features specific to domain internal BIS-BIS communications ».

AVO_230: « Verify the Ground/Ground BIS interworking for various subnetwork adjacencies »: an X.25 WAN

AVO_240: « Verify that data packets follow alternate paths and maintain communication after failure of a network component »

AVO_241: « Verify that BISs can sustain a BIS-BIS connection for a long period of time to support a 'typical' routing information exchange»: Case of a symmetric traffic. »

AVO_242: « Verify the ability of the IDRP protocol to choose the better route for a given criteria (minimal distance) »

AVO_243: « Verify the stability of the IDRP: ability to converge in the updating of the routing table in sufficient time to avoid loss of transport connections and to maintain end-to-end QoS. »

6.3 Raised issues - Recommendations

No new issue has been raised by this exercise.

7. High-level Specification of AVE_307

7.1 Shortest path update with IDRP.

7.1.1 Exercise Reference

AVE_307

7.1.2 Objective Reference(s)

This exercise aims at covering part of the following objectives: AVO_201, AVO_204, AVO_205, AVO_206, AVO_230, AVO_240, AVO_241, AVO_242, AVO_243

7.1.3 Configuration

This exercise will use configuration AVC_116.

This configuration will comprise three RDs, one of which acts as a Transit Routing Domain.

7.1.4 Specification:

This exercise aims at verifying the IDRP Protocol ability to choose the shortest route between 2 ATN ESs. For each configuration, the exercise will consist in the establishment of all the BIS-BIS connections described on the routing configuration figure. Once the RIBs and FIBs of the BISs have been verified, data will be transmitted between the different ESs of the 2 RDs. Then one of the BISs will be stopped, in order to validate the IDRP Protocol ability to recover from such failures and to find out again the shortest path between two BISs.

7.1.5 Expected results

The RIBs and FIBs of the different systems should be correctly updated, and the shortest route should be chosen for each data transfer.

8. Detailed Specification of AVE_307

8.1 Shortest path update with IDRP

Exercise Reference	Objective(s) Reference	ATN Validation Configuration
AVE_307	AVO_201, AVO_204, AVO_205, AVO_206, AVO_230, AVO_240, AVO_241, AVO_242, AVO_243	AVC_116

8.1.1 Aim of the Exercise

Verify that IDRP protocol is able to choose the shortest route between two ATN End System when required by the routing policy.

Verify that when the network topology is correctly defined, a transport connection is not affected by the failure of an intermediate system.

8.1.2 Initial Conditions

8.1.2.1 Routing Information Base

Intermediate System R1 :

- **Forwarding Information Base :**

Neighbour part : The NET and SNPA address of R2 must be defined through the WAN2 subnetwork.

The NET and SNPA address of R3 must be defined through the WAN1 and WAN2 subnetworks.

Intra Domain part : The NET of R2 and the NLRI of Routing Area RA2 must be defined.

- **Static route definition :**

An external route to Intermediate System R3 must be defined.

An internal route to Intermediate System R2 must be defined.

- **Local Policy**

A local policy must be defined in order to assign a Local route preference value based on the RD_HOP_COUNT.

Intermediate System R2 :

- **Forwarding Information Base :**

Neighbour part : The NET and SNPA address of R1 must be defined through the WAN2 subnetwork.

The NET and SNPA address of R4 must be defined through the WAN2 subnetwork.

Intra Domain part : The NET of R1 and the NLRI of Routing Area RA1 must be defined.

- **Static route definition :**

An external route to Intermediate System R4 must be defined.

An internal route to Intermediate System R1 must be defined.

- **Local Policy**

A local policy based on the RD_HOP_COUNT must be defined in order to assign a Local route preference based on the RD_HOP_COUNT value.

Intermediate System R3 :

- **Forwarding Information Base :**

Neighbour part : The NET and SNPA address of R1 must be defined through the WAN1 and WAN2 subnetworks.

The NET and SNPA address of R4 must be defined through the WAN2 subnetwork.

- **Static route definition :**

An external route to Intermediate System R1 must be defined.

An external route to Intermediate System R4 must be defined.

- **Local Policy**

A local policy based on the RD_HOP_COUNT must be defined in order to assign a Local route preference based on the RD_HOP_COUNT value.

Intermediate System R4 :

- **Forwarding Information Base :**

Neighbour part : The NET and SNPA address of R2 must be defined through the WAN2 subnetwork.

The NET and SNPA address of R3 must be defined through the WAN2 subnetwork.

- **Static route definition :**

An external route to Intermediate System R3 must be defined.

An external route to Intermediate System R2 must be defined.

- **Local Policy**

A local policy based on the RD_HOP_COUNT must be defined in order to assign a Local route preference based on the RD_HOP_COUNT value.

8.1.2.2 System Configuration

Intermediate systems R1 and R3 must be configured in order to use the LAN 8802 SNDCF, two X25 standard SNDCF and the IDRP protocol.

Intermediate systems R2 and R4 must be configured in order to use the LAN 8802 SNDCF, one X25 standard SNDCF and the IDRP protocol.

End systems H1, H2, H3 and H4 must be configured in order to use an unique LAN 8802 SNDCF.

8.1.3 Traffic Profiles

A connection oriented transport scenario will be used to exchange TPDU between H1-H2, H2-H3 and H3-H1. End Systems H1, H2 and H3 will run an echoed mode scenario using the following parameters :

number of connections	1
data unit size	CONSTANT
data unit length	100
data transmission frequency type	CONSTANT
data transmission period	8s for the scenario on H1, 3s on H2 and 5s on H3
data unit number	40 for the scenario on H1, 30 for H2 and H3
data unit content	BINARY
use checksum	Y

8.1.4 Points of observation

Activate the IDRP traces in R1, R2, R3 and R4.

Activate the FIB display interface on R1, R2, R3 and R4.

Activate the X25 traces on R1, R2, R3 and R4.

Activate the COTP traces on H1, H2 and H3.

8.1.5 Network Operator Action

N/A.

8.1.6 Test sequencing

The operator has to achieve in sequence the following operations :

Step 1 :

1. Start all the systems.
2. Activate IDRP traces as well as the FIB display interface on R1, R2, R3, R4.
3. Launch the TSTG process on H1, H2 and H3.
4. Activate the COTP traces on H1, H2 and H3.
5. Run the TSTG scenario on H1.
6. Run the TSTG scenario on H2.
7. At the end of the scenarii, stop all the systems

Step 2 :

1. Start all the systems.
2. Activate IDRP traces as well as the FIB display interface on R1, R2, R3, R4.
3. Launch the TSTG process on H1, H2 and H3.
4. Activate the COTP traces on H1, H2 and H3.
5. Run the TSTG scenario on H2.
6. Shutdown the intermediate system that is in use between R2 and R3 (it will be either R4 or R1)
7. At the end of the scenario, shutdown all the systems.

8.1.7 Expected Results

Step 1 :

- **Each routing domain must discover dynamically his neighbour routing domain.**

The FIB traces file shall contain :

Intermediate system R1 :

The ES neighbour part must contain both NSAP and SNPA addresses of H1.

The IS neighbour part must contain :

NSAP and SNPA addresses of R2 through the WAN2 subnetwork.

NSAP and SNPA addresses of R3 through the WAN1 and WAN2 subnetworks.

The Intra-Domain part must contain an entry to reach RA2 through R2.

The Inter-Domain part must contain :

An entry to reach RD1 through R3.

An entry to reach RD4 through R2. or R3

Intermediate system R2 :

The ES neighbour part must contain both NSAP and SNPA addresses of H2.

The IS neighbour part must contain :

NSAP and SNPA addresses of R1 through the WAN2 subnetwork.

NSAP and SNPA addresses of R4 through the WAN2 subnetwork.

The Intra-Domain part must contain an entry to reach RA1 through R1.

The Inter-Domain part must contain :

An entry to reach RD3 through R4.

An entry to reach RD1 through R1 or R4.

Intermediate system R3 :

The ES neighbour part must contain both NSAP and SNPA addresses of H3.

The IS neighbour part must contain :

NSAP and SNPA addresses of R1 through the WAN1 and WAN2 subnetworks.

NSAP and SNPA addresses of R4 through the WAN2 subnetwork.

The Inter-Domain part must contain :

An entry to reach RD3 through R4.

An entry to reach RD2 through R1

Intermediate system R4 :

The ES neighbour part must contain both NSAP and SNPA addresses of H4.

The IS neighbour part must contain :

NSAP and SNPA addresses of R2 through the WAN2 subnetwork.

NSAP and SNPA addresses of R3 through the WAN2 subnetwork.

The Inter-Domain part must contain :

An entry to reach RD1 through R3.

An entry to reach RD2 through R2.

- **End System H1 must be able to establish a reliable transport connection with H2 through the WAN2 subnetwork between R1 and R2.**

The CLNP traces file on R1 shall contain :

When receiving NPDU coming from H1 to H2, Intermediate System R1 must send this NPDU directly to R2 through WAN2.

The CLNP traces file on R2 shall contain :

When receiving NPDU coming from H2 to H1, Intermediate System R2 must send this NPDU directly to R1 through WAN2.

The report scenario file on H1 shall contain :

The report generated by the TSTG in H1 shall state that no TPDU has been lost

- **End System H2 must be able to establish a reliable transport connection with H3.**

The CLNP traces file on R3 shall contain :

When receiving an NPDU coming from H3 for H2, Intermediate System R3 must send this NPDU to R2 via R1.

The CLNP traces file on R2 shall contain :

When receiving an NPDU coming from H2 to H3, Intermediate System R2 must send this NPDU to R3 via R1.

The report scenario file on H2 shall contain :

The report generated by the TSTG in H2 shall state that no TPDU has been lost

Step 2 :

- **Each routing domain must be able to recover dynamically from the R1 shutdown.**

The FIB traces file shall contain :

Intermediate system R2 :

The ES neighbour part must contain both NSAP and SNPA addresses of H2.

The IS neighbour part must contain :

NSAP and SNPA addresses of R4 through the WAN2 subnetwork (static definition).

NSAP and SNPA addresses of R1 through the WAN2 subnetwork (static definition).

The Intra-Domain part must contain an entry to reach R1 directly (static definition).

Before R1 is stopped, the Inter-Domain part must contain :

An entry to reach RD1 through R1.

An entry to reach RD3 through R4.

When R1 is stopped, the Inter-domain part must be updated as follows:

An entry to reach RD1 through R4.

An entry to reach RD3 through R4.

Intermediate system R3 :

The ES neighbour part must contain both NSAP and SNPA addresses of H3.

The IS neighbour part must contain :

NSAP and SNPA addresses of R1 through the WAN1 and WAN2 subnetworks.

NSAP and SNPA addresses of R4 through the WAN2 subnetwork.

Before R1 is stopped, the Inter-Domain part must contain :

An entry to reach RD3 through R4.

An entry to reach RD2 through R1.

When R1 is stopped, the Inter-domain part must be updated as follows:

An entry to reach RD3 through R4.

An entry to reach RD2 through R4.

Intermediate system R4 :

The ES neighbour part must contain both NSAP and SNPA addresses of H4.

The IS neighbour part must contain :

NSAP and SNPA addresses of R2 through the WAN2 subnetwork (static definition).

NSAP and SNPA addresses of R3 through the WAN2 subnetwork.

The Inter-Domain part must contain :

An entry to reach RD1 through R3.

An entry to reach RD2 through R3.

- **End System H2 must be able to establish a reliable transport connection with H3 via R1, then R4.**

The CLNP traces file on R2 shall contain :

When receiving NPDU coming from H2 destined to H3, Intermediate System R2 must send this NPDU to R3 via R1, then via R4 when R1 is stopped.

The CLNP traces file on R3 shall contain :

When receiving NPDU coming from H3 destined to H2, Intermediate System R3 must send this NPDU to R2 via R1, then via R4 when R1 is stopped.

The COTP traces file on H2 and H3 shall contain :

When R1 is stopped, some TPDU's can be retransmitted before the new path is established.

The report scenario file on H2 shall contain :

The report generated by the TSTG in H2 shall state that no TPDU has been lost