

APPENDIX 6 ATN ROUTING

Exchange between Systems - OSI Routing Framework

- 4) ISO 8208 - Information Technology - Data Communications - X.25 Packet Layer Protocol for Data Terminal Equipment (Revision of Second Edition)

A6.1 Introduction

A6.1.1 Scope

This appendix provides requirements and recommendations pertaining to the deployment of ATN components within the ATN Internet; use of routing information distributed according to ISO/IEC 10747 in order to support policy based and mobile routing in the Aeronautical Telecommunications Network; and the Route Initiation procedures for initiating the exchange of routing information using the ISO/IEC 10747 protocol. In the case of air-ground data links, route initiation also includes the use of the ISO/IEC 9542 protocol. This appendix is not concerned with compliancy with the ISO/IEC 10747 and ISO/IEC 9542 protocols. This is the subject of appendix 11.

A6.1.2 References

- 1) ISO/IEC 10747:1993 - Information Processing Systems - Telecommunications and Information Exchange between Systems - Protocol for exchange of inter-domain routing information among intermediate systems to support forwarding of ISO 8473 PDUs (IDRP)
- 2) ISO/IEC 9542:1988 - Information Processing Systems - Telecommunications and Information Exchange between Systems - ES to IS routing exchange protocol for use in conjunction with the Protocol for providing the connectionless-mode network service (ISO 8473)
- 3) ISO TR 9575:1993 - Information Technology - Telecommunications and Information

A6.1.3 Applicability of Requirements

Note 1. The classes of ATN Router referred to below are defined in AA6.2.

Note 2. The ATN RDs referred to below are defined in AA6.3.1.

ATN Ground-Ground Routers shall comply with the provisions of AA6.4 and A0. When used as an ATN Router in an ATN RD that is a member of an ATN Island Backbone RDC, an ATN Ground-Ground Router shall also comply with the provisions of AA6.7.1. When used in any other ATN Transit Routing Domain, an ATN Ground-Ground Router shall also comply with the provisions of AA6.7.3. Otherwise, an ATN Ground-Ground shall comply with the provisions of AA6.7.4.

ATN Air/Ground Routers shall comply with the provisions of AA6.4 for ground-ground interconnection, AA6.5 for air/ground interconnection and A0. When used as an ATN Router in an ATN RD that is a member of an ATN Island Backbone RDC, an ATN Air/Ground Router shall also comply with the provisions of AA6.7.1. When used in any other ATN Transit Routing Domain, an ATN Air/Ground Router shall also comply with the provisions of AA6.7.3.

ATN Airborne Routers shall comply with the provisions of AA6.5, A0, and AA6.7.2.

When an RD is declared to be an ATN RD then it shall comply with the provisions of AA6.3.2.

When an RD is declared to be a Mobile RD, then it shall comply with the provisions of AA6.3.2.3.

When an RDC is declared to be an ATN Island RDC then its member RDs shall comply with the provisions of AA6.3.3.2

When an RDC is declared to be an ATN Island Backbone RDC then its member RDs shall comply with the provisions of AA6.3.3.3.

A6.2 ATN Routers

The classes of ATN Router and the Routing Protocols supported, that are recognised by this specification, are listed below in Table AA6-1:

	Name	Routing Protocols Supported
1.	Static Router	ISO 9542 (optional)
2.	Level 1 Router	ISO 9542 (optional) ISO/IEC 10589 Level 1 only
3.	Level 2 Router	ISO 9542 (optional) ISO/IEC 10589 Level 1 and Level 2
4.	Ground-Ground Router	ISO 9542 (optional) ISO/IEC 10589 (optional) ISO/IEC 10747
5.	Air/Ground-Router (ground based)	ISO 9542 ISO/IEC 10589 (optional) ISO/IEC 10747 Route Initiation Procedures (see AA6.5.2)
6.	Airborne Router with IDRP	ISO 9542 ISO/IEC 10747 Route Initiation Procedures (see AA6.5.2)
7.	Airborne Router without IDRP	ISO 9542 Route Initiation Procedures (see AA6.5.2)

Table AA6-1 ATN Router Classes

Note 1. Classes 1, 2 and 3 are only for use within an ATN Routing Domain and their specification is a local matter.

Note 2. The intra-domain parts of Router Classes 4 and 5 are also a local matter.

Note 3. The intra-domain part of Router Class 6 and 7 are concerned with the interconnection of avionics to the airborne router and are the subject of aeronautical industry standards.

Note 4. Router Classes 5, 6 and 7 describe routers that support at least one ATN Mobile Subnetwork.

All ATN Inter-Domain Routers (i.e. Router Classes 4 to 7 inclusive) shall support:

- a) the ISO 8473 Connectionless Network Protocol (CLNP) as specified in Appendix 9, including the use of the CLNP options security parameter, and shall interpret and obey the Routing Policy Requirements expressed therein, whilst routing the packet in accordance with any restrictions placed on the traffic types that may be carried over a given ATN Subnetwork, by forwarding CLNP NPDUs according AA6.8, and using FIBs built according to the procedures of AA6.6.4.
- b) the ISO 10747 Inter-Domain Routing Protocol (IDRP) as specified in appendix 11 for the exchange of inter-domain routing information according to A0 and AA6.7.

An Airborne (Router Classes 6 or 7) or Air/Ground Router (Router Class 5) shall support the Mobile Sndcf specified in appendix 10 for the use of CLNP over an ATN Mobile Subnetwork, and the ISO 9542 ES-IS routing information exchange protocol, as specified in appendix 11 for support of the route initiation procedures specified in AA6.5.2.

A6.3 The Deployment of ATN Components

A6.3.1 Routing Domains

The ATN shall consist of a set of interconnected Routing Domains (RDs), within the global OSI Environment (OSIE). Each such RD shall contain *Air Traffic Service Communication (ATSC)* and/or *Aeronautical Industry Service Communication (AINSC)* related Intermediate and End Systems. A Routing Domain that declares itself to be a Transit Routing Domain (TRD) shall implement a Routing Policy that supports the relaying of NPDUs received from at least one other Routing Domain to destinations in another Routing Domain. Otherwise, the Routing Domain shall be defined as an End Routing Domain (ERD).

A6.3.2 ATN RDs

An ATN RD is a Routing Domain that includes one or more ATN Routers.

Every ATN RD shall have a unique Routing Domain Identifier (RDI).

Note.— An RDI ~~is~~ *is* a generic Network Entity Title (NET), and has the same syntax as an ATN NSAP Addresses; alias RDIs are permitted.

A6.3.2.1 Administration RDs

Each Administration participating in the ATN shall operate one or more ATN Routing Domains (RDs), comprising Air/Ground and Ground-Ground Routers as required to interconnect with Mobile RDs and other ground based ATN RDs, respectively ~~which may be either Transit Routing Domains (TRDs) or End Routing Domains (ERDs), operating under the applicable routing policies specified in Clause 6.3.~~

Note.— Adjacent Administrations may alternatively combine their RDs into a single RD.

A6.3.2.2 Aeronautical Industry RDs

Each aeronautical industry member participating in the ATN shall operate one or more Routing Domains (~~RDs~~ RDs, comprising Air/Ground and Ground-Ground Routers as required to interconnect with Mobile RDs and other ground based ATN RDs, respectively), ~~operating under the routing policies in accordance with 6.3.~~

Note 1.— ~~These RDs may be either Transit Routing Domains (TRDs) or End Routing Domains (ERDs).~~

Note 2.— Adjacent aeronautical industry domains may alternatively combine their RDs into a single RD.

A6.3.2.3 Mobile RDs

Each ATN equipped mobile platform (e.g. an aircraft), shall operate at least one ATN RD. This shall be an End Routing Domain. This ERD shall include all ATSC and AINSC related Intermediate and End Systems on board that aircraft, and at least one Airborne Router (Router Class 6 or 7), ~~and shall operate the routing policy in accordance with 6.3.~~

Note 1.— An ATN mobile platform may operate multiple ERDs.

Note 2.— It is anticipated that other classes of mobile platforms (e.g. airport surface vehicles, etc.) may operated as ATN routing domains in the future.

A6.3.3 Routing Domain Confederations (RDCs)

Each ATN Ground-Ground or Air/Ground Router ~~BIS that is located in an ATN RD and which is a member of~~ participates in one or more RDCs ~~confederations~~ shall be configured with ~~aware~~ of the RDIs of all RDCs ~~confederations~~ of which it is a member, and it shall know the partial order which prevails between these RDCs ~~confederations~~; that is, it shall be configured with the nesting and overlapping relationships between all RDCs ~~confederations~~ to which it belongs.

Note 1.— Formation of an RDC is done via a private arrangement between its members without any need for global co-ordination. From the outside, an RDC appears like a single RD: for example, it has an identifier which is an RDI, and RD_Path information records the transit through the RDC as a whole, rather than through each RDC member RD. Other RDs can develop policies with respect to the RDC ~~confederation~~ as a whole, as opposed to the individual RDs that are members of the RDC ~~confederation~~. RDCs ~~Confederations~~ can be disjoint, nested or overlapping. Each RD within a RDC ~~confederation~~ may have its own set of routing policies: that is, different RDs in the same RDC ~~confederation~~ can have different policies.

The ATN shall be organized into the Routing Domain Confederations (RDCs) specified below.

Note 2.— Other RDCs may be formed by private arrangement.

A6.3.3.1 Fixed ATN RDC

The Fixed ATN RDC shall comprise all ATN RDs other than Mobile RDs.

Note.— The Fixed ATN RDC enables a ground ATN Router ~~BIS~~ to advertise a route to a mobile, the destination of which is the entire fixed ATN, without having to enumerate the RDIs of all ATN RDs ~~RDs~~ in the RD_Path Attribute.

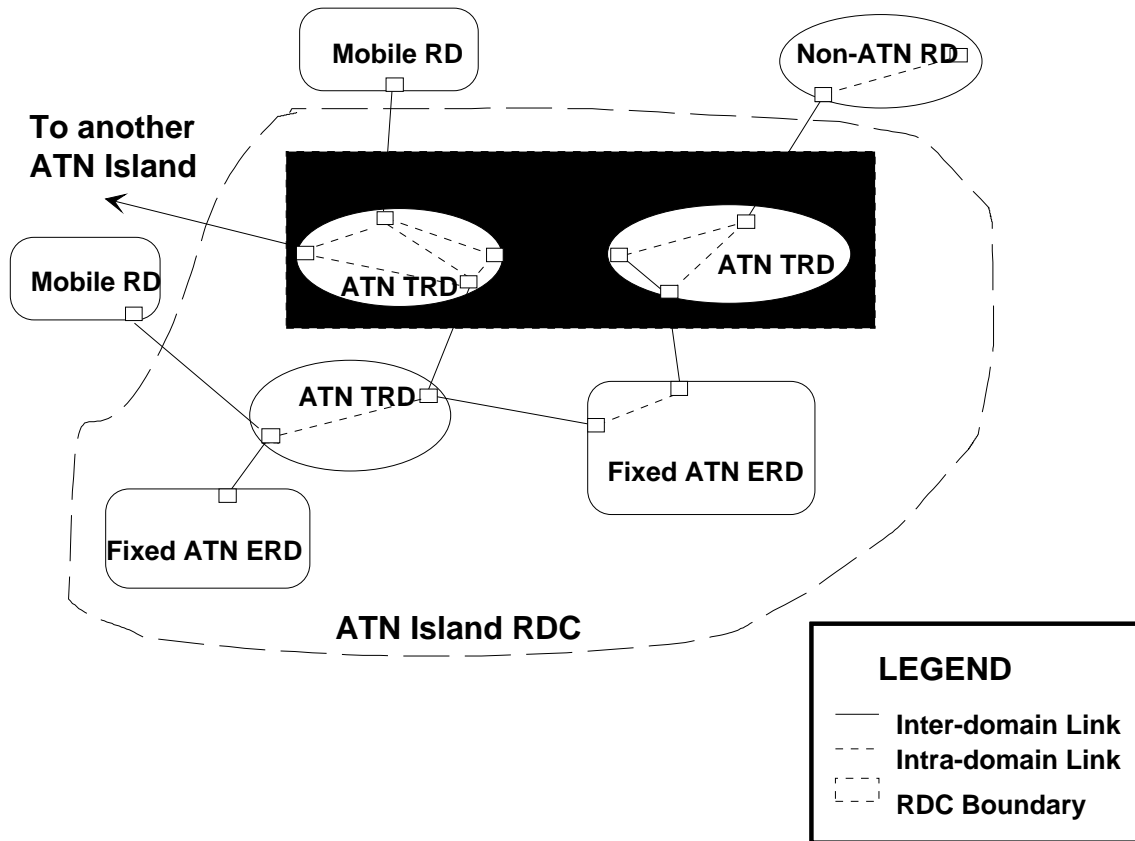

Figure AA6-1 Example ATN Island Routing Domain Confederation Structure

A6.3.3.2 ATN Island RDCs

An ATN Island RDC shall be nested within the Fixed ATN RDC, and shall comprise:

- a) one or more ATN RDs, operating Routing Policies in compliance with AA6.7.1 or AA6.7.3, and
- b) exactly one ATN Backbone RDC, and comprises either:

Note 1. The purpose of the ATN Island is to define the domain of a default route provider for routes to mobile systems. Within the ATN, there may be many such default route providers, and hence many ATN Islands.

Note 2. The Backbone RDC identifies the default route provider for each ATN Island.

Recommendation. An ATN RDs should shall be a member of at least one organize themselves into ATN Island RDCs.

Note 3. In order to participate in Air-Ground Routing, either as a service provider or a user, an ATN RD has to be a member of at least one ATN

Island. ATN RDs that are not a member of any ATN Island RDC are unable to communicate with airborne systems, except via direct use of locally connected air-ground subnetworks.

Administration operated ATN RDs within a geographic region, together with the RDs of zero, one or more ATN service providers providing communications services to those Administration operated ATN Rds, or

Aeronautical Industry members which are the users of communications services of either a single Aeronautical Industry Service Provider, or more than one such provider providing services in combination with each other.

Note 4.— An ATN RD is not restricted to membership of a single ATN Island RDC.

A6.3.3.3 ATN Island Backbone RDCs

Editor's Note. I noticed two very similar terms when editing this section: Backbone RD and Backbone RDC, of which only the latter was defined. I have tried to avoid potential confusion by editing out the former term.

An ATN Backbone RDC shall be nested within an ATN Island RDC, and comprises one or more ATN RDs operating Routing Policies consistent with the definition of a Transit Routing Domain and in compliance with AA6.7.1.

~~When there exist within an ATN Island RDC, multiple RDs which operate as a Transit Routing Domains and are able to provide routes to all ATN RDs within the ATN Island RDC, then at least one of these shall take on the role of the island's Backbone RD. When there is more than one Backbone RD, then these RDs shall form an ATN Island Backbone RDC, nested within the ATN Island RDC.~~

Note.— The purpose of the Backbone RDC is to permit more than one ATN RD to act as the default route provider for an ATN Island. It also provides a containment boundary to the Backbone RDC ensures that the Backbone RDs can implement a straightforward routing policy that limits the impact of changes in routes to mobile RDs, to only the members of the Backbone RDC and not to the rest of the ATN Island.

A6.3.3.4 Other ATN RDCs

Recommendation.— When considered appropriate for administrative, security or operational reasons, ATN RDs should also form RDCs in order to define useful groups of ATN RDs.

Note.— The purpose and extent of such RDCs is beyond the scope of this standard.

A6.3.4 Administrative Domains and the ATN

The Administrative Domain of each administration, and aeronautical industry member that operates one or more ATN RDs shall comprise both their ATN RDs, and any non-ATN RDs that they operate.

Note.— The Routing Policies for communication between ATN and non-ATN RDs within the same Administrative Domain is a local matter.

A6.3.5 Interconnection Scenarios

ATN RDs shall be interconnected by real subnetworks permitting communication between ATN Routers ~~Boundary Intermediate Systems (BISs)~~ for each of the interconnection scenarios specified below.

Note 1. Examples of possible interconnections between ATN Routing Domains are and illustrated in Figure AA6-1

Note 21.— There is no requirement for all ATN RDs to be fully interconnected.

Except for the interconnection of Mobile RDs with other ATN RDs, the real subnetwork used for such an interconnection shall be chosen by bilateral agreement and may be any subnetwork that can be used to convey supports the ISO 8473 protocol and provides the required quality of service.

Note 32.— For example, the chosen subnetwork may be a point-to-point communications link, a public or private PSDN providing the CCITT X.25 network access service, an Ethernet or an ISDN, etc.

Note 4. The Dynamic procedures for the interconnection of two ground based ATN Routers are specified in AA6.4, and for interconnection of an Air/Ground and an Airborne Router in AA6.5. The remainder of this section is concerned with static interconnection requirements.

A6.3.5.1 Interconnection between Members of an ATN Island Backbone RDC

When there is more than one ATN Backbone RD in an ATN Island Backbone RDC, each Administration or Aeronautical Industry Member that has elected to participate in that ATN Island's Backbone RDC, shall ensure that its RD is either:

- a) interconnected directly with all other ATN RDs within the ATN Island's Backbone RDC, over a suitable and mutually agreeable real subnetwork or
- b) interconnected directly as above, with one or more ATN Backbone RDs ~~RDs~~ that are also members of the ATN Island's Backbone RDC, and which are able and willing to provide routes to the remaining ATN Backbone RDs within the Backbone RDC.

Note.— The existence of the ATN Backbone RDC prohibits routes between its member ~~ATN Backbone RDs~~ via other ATN RDs in the same ATN Island ~~non-ATN Backbone RDs~~.

A6.3.5.2 Interconnection of Between Members of an ATN Island Backbone RDC and other ATN RDs within the ATN Island

ATN RDs within an ATN Island RDC that are not members of the ATN Island's Backbone RDC, ~~or are not the Backbone RD~~, shall ensure that they are either:

- a) interconnected directly with one or more ~~ATN Backbone RDs that are members of the within the same ATN Island's Backbone RDC~~, over suitable and mutually agreeable real subnetworks; or
- b) interconnected with one or more ~~other ATN non-ATN Backbone RDs~~ that are members of the same ATN Island RDC and which are able and willing to provide routes to and from one or more ATN ~~Backbone RDs~~ within the same ATN Island's Backbone RDC, and to all destinations reachable via the ATN Island's Backbone.

A6.3.5.3 Interconnection of ATN Islands

ATN Islands shall only interconnect via ATN RDs which are either ~~the Backbone RDs of each island, or members of each ATN Island's~~ Backbone RDC.

When an ATN RD is a member of more than one ATN Island RDC, its routing policy shall not permit it to operate as a TRD between sources and destinations in different ATN Islands unless the RD is ~~the Backbone RD for each island, or a member of each island's~~ Backbone RDC.

A6.3.5.4 Interconnection of Mobile and Fixed RDs

Note.— A Mobile RD may interconnect concurrently with any ATN RDs which are attached to the mobile subnetworks and which are accessible to the Mobile RD at any given time.

A6.3.5.5 Interconnection of ATN RDs and non-ATN RDs

Note.— ATN RDs may interconnect with non-ATN RDs whether they are members of the same Administrative Domain or not.

A6.4 Ground-Ground Interconnection

A6.4.1 Interconnection Scenarios

Note 1. Ground-Ground interconnection procedures apply to the interconnection of two Ground-Ground Routers, and to the interconnection of an Air/Ground Router and a Ground-Ground Router.

Note 2. Formally, these procedures only apply to interconnection between ATN Routers in different Administrative Domains. However, in practice, they are also applicable to interconnection scenarios within the same Administrative Domain.

A6.4.2 Ground-Ground Route Initiation

Note 1. Route Initiation is defined to be the point at which routing information exchange can begin, and the route initiation procedures are those that permit the exchange of routing information to commence.

When the Network Administrators agree to the Ground-Ground interconnection of one or more ATN Routers within their Administrative Domains, they shall:

- a) Make available suitable subnetwork connectivity including, where necessary the physical installation of suitable communications equipment for end-to-end communications between the ATN Routers, and supporting the Quality of Service necessary for the applications data that will be routed over this interconnection.

Note 2. The choice of appropriate subnetwork(s) to support the interconnection is a matter for bilateral agreement between network administrators, including agreement on responsibility for installation, operating and maintenance costs, and fault management.

- b) Using global or local Systems Management mechanisms, establish one or more subnetwork connections between the two ATN Routers, unless the subnetwork technology is connectionless when this step may be omitted.

Note 3. Typically (e.g. with X.25), one ATN Router will be placed in a state where it will accept an incoming connection from the other

ATN Router, and then the other ATN Router is stimulated to initiate one or more subnetwork connection(s) to the other ATN Router.

Note 4. Multiple concurrent subnetwork connections over the same or different subnetworks may be required in order to meet throughput and other QoS requirements.

- c) Using global or local Systems Management mechanisms, ensure that the forwarding information base in each ATN Router, used to support the connectionless network protocol specified in appendix 9, contains sufficient information to forward CLNP NPDUs addressed to the NET of the other ATN Router, over the newly established subnetwork connection(s).

Note 5. This step is necessary to ensure that the connectionless network service can be used to exchange the BISPDU's of IDRP.

- d) Using global or local Systems Management mechanisms:
 - i) append the NET of the remote ATN Router to the **externalBISNeighbor** attribute of the BIS's **idrpConfig** MO,
 - ii) create an **AdjacentBIS** Managed Object (MO) in each ATN Router to represent the other ATN Router, and
 - iii) invoke the start event action on each such MO, in order to initiate a BIS-BIS connection between the two ATN Routers.

*Note 6. As a matter for the bilateral agreement of the Network Administrators, either (a) both ATN Routers will attempt to open the BIS-BIS connection using the active open procedures, that is with the **ListenForOpen** MO attribute set to false, or (b) one and only one sets this attribute to true.*

A6.4.3 Ground-Ground Routing Information Exchange

Routing information shall be exchanged using the ISO/IEC 10747 Inter-Domain Routing Protocol according to the profile specified in appendix 11. In support of Air/Ground communications, the exchange of routing information shall be subject to appropriate routing policies specified in AA6.7.1, AA6.7.3, or AA6.7.4, depending upon the role of

the Routing Domain in which each ATN Router is located.

A6.4.4 Ground-Ground Route Termination

Note 1. Route Termination is defined to be the point at which routing information ceases to be exchanged between two ATN Routers, and, in consequence, the routes made available over the adjacency cease to be useable and must be withdrawn. The route termination procedures are those procedures which terminate the exchange of routing information.

Note 2. Route Termination may result from a failure in the underlying subnetworks causing a loss of communication between the two ATN Routers. Alternatively, it may result from a deliberate decision of Network Administrators to terminate the interconnection, either temporarily or permanently.

Note 3. No special recovery procedures are specified if route termination is due to a network fault. Once the fault has been repaired, the procedures of AA6.4.2 are re-invoked, as appropriate to re-establish communication, and to exchange routing information.

When a Network Administrator decides to temporarily or permanently terminate an interconnection between two ATN Routers then, using global or local Systems Management mechanisms applied to either or both of the two ATN Routers, the **deactivate** action shall be invoked on the **AdjacentBIS** MO that represents the remote ATN Router with which the BIS-BIS connection is to be terminated.

If the adjacency is to be permanently terminated, then the **AdjacentBIS** MO shall also be deleted, and the forwarding information base shall be updated to remove the route to the NET of the remote ATN Router.

For either temporary or permanent termination, and if required, by using global or local Systems Management mechanisms, the Network Administrator(s) shall also terminate the underlying subnetwork connections.

A6.5 Air-Ground Interconnection

Editor's note: in this section I have reorganised the text to remove the considerable redundancy in the original text, rather than have to duplicate in several different areas, the procedures for the optional non-use of IDRP.

A6.5.1 Interconnection Scenarios

Note 1. Air-Ground interconnection applies to the interconnection between an ATN Airborne Router and an ATN Air/Ground Router over one or more mobile subnetworks.

Note 2. The significant difference between Air-Ground and Ground-Ground Interconnection is that in the former case interconnection is automatic and consequential on the availability of communications and local policy, while, in the latter case, interconnection is a deliberate and planned action with the direct involvement of Network Administrators.

Note 3. While IDRP is also intended to be used over Air-Ground Interconnections, as an interim measure, the optional non-use of IDRP over Air-Ground Interconnections is permitted by this specification and according to AA6.5.2.10.

Note 4. For the purposes of this specification, the functional model of a Router illustrated in Figure AA6-2 is assumed. This model illustrates the basic functional entities in a router, the data flow between them as thick lines, and the flow of certain events and control information, by dashed lines.

Note 5. Figure AA6-2 introduces a new architectural entity, the Intermediate System - Systems Management Entity (IS-SME). As specified below, this plays an important role in the realisation of Route Initiation in Air/Ground Operations, by responding to changes in subnetwork connectivity and thereby controlling the route initiation and termination procedures.

A6.5.2 Air-Ground Route Initiation

BIS-BIS communications over a mobile~~an air-ground~~ subnetwork shall be either air-initiated or ground-initiated, with one of these two modes of operation selected for all instances of a given subnetwork type.

Note 1. Two classes of procedure are distinguished by this specification. These are: (a) Air Initiated i.e. when the Airborne Router initiates the procedure, and (b) Ground Initiated i.e. when the Air/Ground Router initiates the procedure.

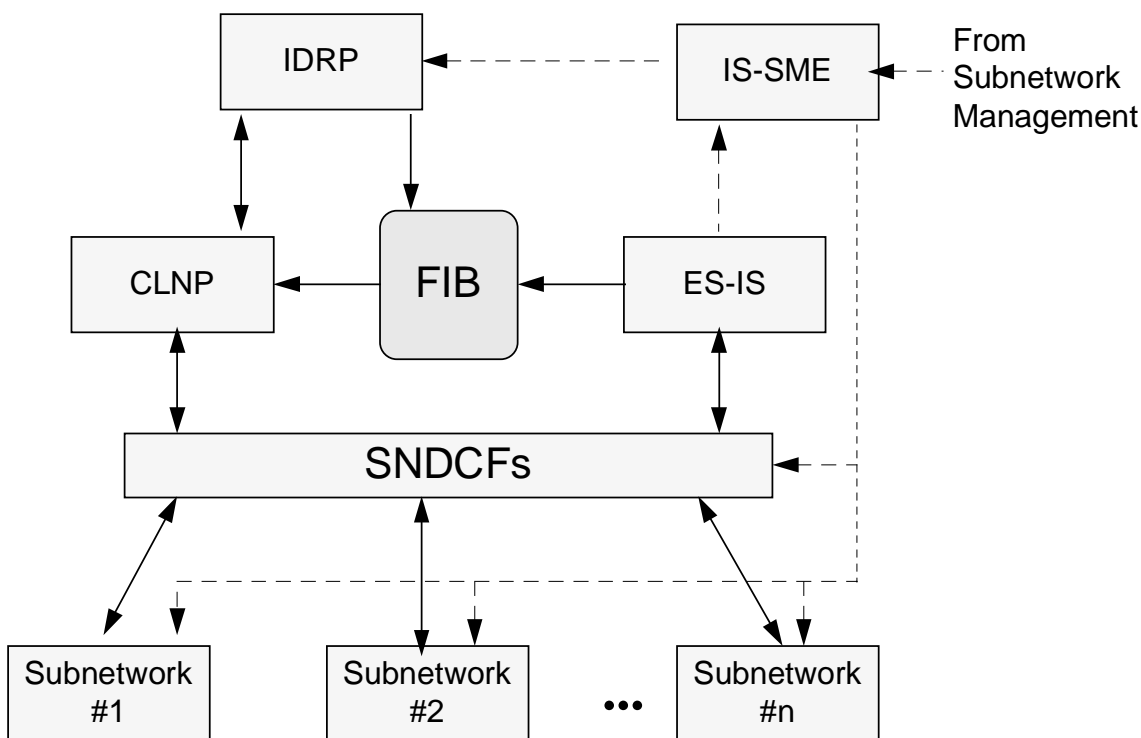

Figure AA6-2 Assumed ATN Router Architecture for Air/Ground Route Initiation

Note 2. Two types of mobile subnetwork are also recognised by this specification. These are: (a) those which provide information on the availability of specific mobile systems on the subnetwork through the Join Event defined in this section, and (b) those which do not. The latter type are only appropriate to Route Initiation Procedures which are Air Initiated.

Note 3. For a given mobile subnetwork type, the use of air-initiated or ground-initiated procedures, and the implementation of Join Events is outside of the scope of this specification, and is a matter for the SARPs specified by the relevant ICAO panel.

Note 4. The interfaces to all mobile subnetworks are assumed to be compatible with ISO 8208. The ISO 8208 term DTE is also used in this specification to refer to a system attached to a mobile subnetwork.

For Air-Initiated Subnetworks that do not provide information on the availability of specific mobile systems, Airborne Routers shall comply with the procedures specified in AA6.5.2.2.1, and

Air/Ground Routers shall comply with the procedure specified in AA6.5.2.1.

For Air-Initiated Subnetworks that do provide information on the availability of specific mobile systems, Airborne Routers shall comply with the procedures specified in AA6.5.2.2.2, and Air/Ground Routers shall comply with the procedure specified in AA6.5.2.1.

For Ground-Initiated Subnetworks, Air/Ground Routers shall comply with the procedures specified in AA6.5.2.3, and Airborne Routers shall comply with the procedure specified in AA6.5.2.1.

A6.5.2.1 Route Initiation Procedures for a Responding ATN Router

Note 1. Route Initiation is always asymmetric with a clearly defined initiator and responder. In all cases, the ATN Router in the responder role, follows the same procedures, as specified below.

Note 2. For Air-Initiated Route Initiation, the Air/Ground Router is the responding ATN Router.

For Ground-Initiated Route Initiation, the Airborne Router is the responding ATN Router.

Each ATN Router that is specified to take the responder role for a given Mobile Subnetwork type, and when attached to a subnetwork of that subnetwork type, shall be configured into a state whereby it "listens" for incoming Call Requests on that subnetwork.

For each incoming Call Request received, a responding ATN Router shall either:

- a) Accept the incoming call immediately using a Call Accept Packet
- b) Validate the calling DTE and either accept the call using a Call Accept Packet, or if the call is unacceptable then it shall be rejected using a Clear Indication Packet

Note 3.— Whenever such a Call Indication is received ~~the ATN~~ ~~the Ground Router~~ ~~BIS~~ may validate the calling DTE and determine the acceptability of the call, using procedures outside of the scope of this specification.

Note 4. The number of simultaneous virtual circuits that the ATN Router needs to support will be subject to an implementation limit, that needs to be sufficient for the role in which the Router is deployed.

When a subnetwork connection is successfully established, then the procedures of AA6.5.2.4 shall be applied to that subnetwork connection.

A6.5.2.1.1 Emergency Use of a Mobile Subnetwork

In the case of Air-Initiated Mobile Subnetworks, an Air/Ground Router ~~BIS~~ shall not refuse a valid Call Request or refuse to establish a BIS-BIS connection with an ~~recognized~~ ATN Airborne Router ~~BIS~~, when a Call Request from the ATN Airborne Router ~~BIS~~ is received less than 5 minutes after a Call Request was rejected, or a call terminated by Systems Management, as discussed above. The Air/Ground Router shall permit, through the implementation of an appropriate routing policy, the use of a so established connection for emergency and distress data.

Note 53.— This situation arises when the Airborne Router ~~BIS~~ has no other air-ground connectivity, and refusal to accept a connection may cause a safety hazard. ~~An~~ ~~hazard~~. However, A Air/Ground Router ~~BIS~~ may limit the use of such connections

through routing policy, or permit full access, as a local matter.

A6.5.2.2 Air-Initiated Route Initiation

A6.5.2.2.1 Airborne Router Procedures for use of an ISO 8208 Mobile Subnetwork that does not Provide Information on Subnetwork Connectivity

An Airborne Router's ~~BIS~~ ~~IS-SME~~ shall be configured with a list of subnetwork addresses for each mobile subnetwork of this type ~~that~~ ~~which~~ it supports. This list may be either a proper subset of all possible subnetwork addresses on that subnetwork, or may be a complete list of all possible subnetwork addresses.

An Airborne Router's ~~BIS~~ ~~IS-SME~~ shall continually issue an ISO 8208 Call Request to each subnetwork address on each such list with which it does not currently have a subnetwork connection and which is not subject to a back-off period (see AA6.5.2.2.1.1), in turn. The period between each successive Call Request to each subnetwork address on each list shall be configurable from 500 ms to 10 seconds.

When a subnetwork connection is successfully established, then the procedures of AA6.5.2.4 shall be applied to that subnetwork connection. The polling procedure shall continue for the remaining subnetwork addresses on the list.

A6.5.2.2.1.1 Call Request Failure

Whenever a Clear Indication is received in response to a Call Request that indicates rejection by the called DTE, the Airborne Router ~~BIS~~ shall implement a "back off" procedure. The back off procedure shall comprise the effective quarantining of the called subnetwork address for a period configurable on a per subnetwork basis from 5 minutes to 20 minutes. During this period, a Call Request shall not be issued to the subnetwork address.

However, during any period when an Airborne Router ~~BIS~~ does not have any subnetwork connections over mobile subnetworks, then all back off procedures shall be suspended until connectivity is established with at least one Air/Ground Router ~~ground~~ ~~BIS~~.

Note. The purpose of the backoff procedure is to avoid unnecessarily overloading the network with call requests.

A6.5.2.2.2 Airborne Router Procedures for use of an ISO 8208 Mobile Subnetwork that does Provide Connectivity Information

Note 1. The connectivity information is provided as a "Join Event". This is an event generated by a mobile subnetwork when it is recognised that a system has attached to the subnetwork and is available for communication using the subnetwork. The Join Event provides the DTE Address of the newly available system.

Note 2. An actual implementation of a Join Event may concatenate several distinct Join Events as defined above into a single message.

Note 3. For air-initiated subnetworks, the Join Event is received by the IS-SME in the Airborne Router. The mechanism by which it is received is both subnetwork and implementation dependent.

On receipt of a Join Event, the Airborne Router shall either:

- a) Issue an ISO 8208 Call Request with the DTE Address reported by the Join Event as the Called Address, or
- b) Validate the DTE reported by the Join Event as to whether or not a subnetwork connection with it is acceptable according to local Routing Policy. If such a connection is acceptable then an ISO 8208 Call Request shall be issued with the DTE Address reported by the Join Event as the Called Address. Otherwise, the Join Event shall be ignored.

Note 4. — Whenever such a Join Event is received, The Airborne Router initiating BIS may validate the calling DTE that is the subject of the Join Event DTE and determines the acceptability of a subnetwork connection with the so identified ATN Router candidate responding BIS, using procedures currently outside of the scope of this specification.

When a subnetwork connection is successfully established, then the procedures of AA6.5.2.4 shall be applied to that subnetwork connection.

A6.5.2.3 Ground-Initiated Route Initiation

Note 1. Ground-Initiated Route Initiation is only appropriate for Mobile Subnetworks that do provide connectivity information through a Join Event.

Note 2. For ground-initiated subnetworks, the Join Event is received by the IS-SME in the Air/Ground

Router. The mechanism by which it is received is both subnetwork and implementation dependent.

On receipt of a Join Event, the Air/Ground Router shall either:

- a) Issue an ISO 8208 Call Request with the DTE Address reported by the Join Event as the Called Address, or
- b) Validate the DTE reported by the Join Event as to whether or not a subnetwork connection with it is acceptable according to local Routing Policy. If such a connection is acceptable then an ISO 8208 Call Request shall be issued with the DTE Address reported by the Join Event as the Called Address. Otherwise, the Join Event shall be ignored.

Note 3. — Whenever such a Join Event is received, The Air/Ground Router initiating BIS may validate the calling DTE that is the subject of the Join Event DTE and determines the acceptability of a subnetwork connection with the so identified ATN Router candidate responding BIS, using procedures currently outside of the scope of this specification.

When a subnetwork connection is successfully established, then the procedures of AA6.5.2.4 shall be applied to that subnetwork connection.

A6.5.2.4 Exchange of Configuration Information using the ISO 9542 ISH PDU

ATN Airborne and Air/Ground Routers shall implement the ISO 9542 "Configuration Information" Function for use over each mobile subnetwork that they support. Whenever a subnetwork connection is established over a mobile subnetwork, the ISO 9542 Report Configuration Function shall be invoked in order to send an ISH PDU containing the NET of the Airborne or Air/Ground Router network entity's IDR entity over the subnetwork connection.

In the case of an Airborne Router, if it supports the use of IDR for the exchange of routing information over this subnetwork, then the SEL field of the NET inserted into the ISH PDU shall always be set to 00h (a binary pattern of all zeroes). Alternatively, if the Airborne Router implements the procedures for the optional non-use of IDR over this subnetwork then the SEL field of the NET inserted into the ISH PDU shall always be set to FEh (a binary pattern of 1111 1110).

Recommendation: When in the initiator role, an ATN Router should use the ISO 8208 "Fast Select"

facility, and encode the first ISH PDU in the Call Request user data, according to the procedures for the Mobile SNDCF specified in appendix 10.

Recommendation: When in the responder role and the initiator has proposed use of the Fast Select Facility, the ATN Router should encode the first ISH PDU in the Call Accept User Data, according to the procedures for the Mobile SNDCF specified in appendix 10.

Note 1. The purpose of encoding an ISH PDU in call request/accept user data is to minimise the number of messages sent over limited bandwidth mobile subnetworks and the time taken to complete the route initiation procedures.

Whenever an ISO 9542 ISH PDU is received, either as call request/accept user data, or as data sent over the connection, the Record Configuration function is shall be invoked; the routing information necessary for NPDU's to be sent over the subnetwork connection to the indicated NET shall be written into the Forwarding Information Base for use by ISO 8473. A Systems Management Notification shall also be generated to report the arrival of the ISH PDU to the ATN Router's IS-SME~~local Systems Management~~.

A6.5.2.5 Validation of the Received NET

The IS-SME shall, using the received NET to identify the remote ATN Router, validate the acceptability of a BIS-BIS connection with that remote ATN Router. If a BIS-BIS connection is unacceptable, then a Clear Request shall be generated to terminate the subnetwork connection. Forwarding Information associated with the subnetwork connection shall be removed from the Forwarding Information Base.

Note 23.— The acceptability of a BIS-BIS connection with the ATN Router responding BIS identified by the received NET, and for the traffic type indicated, is may be determined using procedures outside of the scope of this specification.

If a BIS-BIS Connection is acceptable then an Air/Ground Router shall apply the procedures of AA6.5.2.6, and an Airborne Router shall apply the procedures of AA6.5.2.7.

A6.5.2.6 Determination of The Routing Information Exchange Procedure by an Air/Ground Router

When the arrival of the ISH PDU is reported to the IS-SME of an Air/Ground Router, then the SEL field of the NET shall be inspected;~~local Systems Management,~~ then if a BIS-BIS connection currently exists with the NET given by the ISH PDU, then no further action shall be taken.

- a) If the SEL field takes the value of 00h (a binary pattern of all zeroes), then this shall be taken to imply that the Airborne Router that sent this ISH PDU supports the use of IDRP for the exchange of routing information. The procedures of AA6.5.2.8 shall be applied.
- b) If the SEL field takes the value of FEh (a binary pattern of 1111 1110), then this shall be taken to imply that the Airborne Router that sent this ISH PDU supports the procedures for the optional non-use of IDRP for the exchange of routing information. The procedures of AA6.5.2.10 shall be applied.

A6.5.2.7 Determination of The Routing Information Exchange Procedure by an Airborne Router

When the arrival of the ISH PDU is reported to the IS-SME of an Airborne Router, then if the Airborne Router support the use of IDRP for the exchange of routing information, then the procedures of AA6.5.2.8 shall be applied. If the Airborne Router supports the procedures for the optional non-use of IDRP for the exchange of routing information, then the procedures of AA6.5.2.10 shall be applied.

A6.5.2.8 Establishment of a BIS-BIS Connection

The IS-SME shall append the if a BIS-BIS connection is acceptable, then the NET received on the ISH PDU shall be appended to the externalBISNeighbor attribute of the BIS's **idrpConfig** Managed Object, if not already present, and an **adjacentBIS** Managed Object created for the remote ATN Router responding BIS identified by this NET, if one does not already exist. An IDRP activate"start event" action shall then be invoked to start the BIS-BIS connection according to ISO/IEC 10747, if such a BIS-BIS connection does not already exist.

If the ISH PDU was received from a subnetwork connection which was established with the local ATN Router in the responder role, then the BIS-

BIS connection shall be established with the ListenForOpen MO attribute set to false. Otherwise, the ListenForOpen MO attribute shall be set to true.

Note 1. This procedure minimises the route initiation exchanges over a bandwidth limited mobile subnetwork. The reversal of initiator and responder roles for the BIS-BIS connection compared with the subnetwork connection ensures the fastest route initiation procedure.

If a BIS-BIS connection was already established with the remote ATN Router, then the IS-SME shall cause the IDRPs Routing Decision function to be invoked in order to rebuild the FIB taking into account the additional subnetwork connectivity. This shall include re-update of the security information contained routes received from the remote ATN Router, according to appendix 11.

The IS-SME shall also check to ensure that the procedures for the optional non-use of IDRPs are not concurrently being applied to routing information exchange with an ATN Router with the same NET over a different subnetwork connection. This is an error and shall be reported to Systems Management; a BIS-BIS connection shall not be established in this case.

Recommendation.— *When a BIS-BIS connection has been established, the periodic transmission of ISH PDUs should be suppressed, except when a watchdog timer is applied to the subnetwork connection (see AA6.5.2.11).*

Note 2. Normally, the IDRPs KeepAlive mechanism is sufficient to maintain a check on the “liveness” of the remote ATN Router. However, when watchdog timers are necessary it is also necessary to ensure a “liveness” check on a per subnetwork connection basis. The ISH PDU fulfils this role.

A6.5.2.9 Exchange of Routing Information using IDRPs

Once a BIS-BIS connection has been established with a remote ATN Router then:

- a) An Airborne Router shall advertise routes to the Air/Ground Router in accordance with the Routing Policy specified in AA6.7.2.
- b) An Air/Ground Router shall advertise routes to the Airborne Router in accordance with the Routing Policy specified in AA6.7.1.3 or AA6.7.3.3 as appropriate for the role of the Air/Ground Router’s RD.

A6.5.2.10 Procedures for the Optional non-use of IDRPs over an air-ground data link

Note. In this case, there is no recommendation to suppress the periodic re-transmission of ISH PDUs according to the ISO 9542 Report Configuration Function. In the absence of IDRPs, this re-transmission is necessary to maintain the “liveness” of the connection.

A6.5.2.10.1 Air/Ground Router

Through the actions of the IS-SME as specified below, an Air/Ground Router shall simulate the existence of a BIS-BIS connection with an Airborne Router that implements the procedures for the optional non-use of IDRPs by implementing the following procedure:

- a) The NET of the remote ATN Router shall be appended to the externalBISNeighbor attribute of the BIS’s idrpConfig Managed Object, if not already present, and an adjacentBIS Managed Object created for the remote ATN Router identified by this NET, if one does not already exist. An Adj-RIB-in and an Adj-RIB-out shall hence be created for this remote ATN Router and for the Security RIB-Att.

Note 1. No activate action will be applied to this MO and the implementation will hence need to be able to process information in the Adj-RIB-in even though the MO is in the “idle” state. There is also no need to ever place routes in the Adj-RIB-out. Implementations may choose to optimise the operation of these procedures with a special interface to IDRPs.

- a) Truncating the NET received on the ISH PDU to the first eleven octets and using the resulting NSAP Address Prefix as the NLRI of a route which is then inserted into the Adj-RIB-in for the remote ATN Router and identified by the Security RIB-Att, as if it had been received over a BIS-BIS connection. This route shall include an RD Path attribute with the received NET as the Routing Domain Identifier of the originating RD, and an empty security path attribute.

Note 2. According to the rules for the update of path information specified in appendix 11, the security path attribute will be updated by the Routing Decision process to include an Air/Ground Subnetwork type security tag and an ATC Class security tag, if this is

appropriate. This procedure is identical to the normal use of IDRP over a mobile subnetwork.

If a subnetwork connection is concurrently established with the remote ATN Router over which the procedure for the optional non-use of IDRP have been applied, then the IS-SME shall not repeat the above procedures for the new subnetwork connection. Instead, the IS-SME shall cause the IDRP Routing Decision function to be invoked in order to rebuild the FIB taking into account the additional subnetwork connectivity. This shall include re-update of the security information contained routes received from the remote ATN Router, according to appendix 11.

The IS-SME shall also check to ensure that a normal BIS-BIS connection does not concurrently exist with an ATN Router with the same. This is an error and shall be reported to Systems Management; the procedures for the optional non-use of IDRP shall not be applied in this case.

A6.5.2.10.2 Airborne Router

An Airborne Router implementing the procedures for the optional non-use of IDRP over a mobile subnetwork shall simulate the operation of IDRP by maintaining a Loc-RIB for the Security RIB Att, which is then used to generate FIB information according to AA6.6.4.2.

Through the actions of its IS-SME, an Airborne Router shall derive entries for this loc RIB from the ISH PDU received from an Air/Ground Router as follows:

- a) The IS-SME shall insert into the loc-RIB, a route derived by truncating the NET received on the ISH PDU to the first eleven octets and using the resulting NSAP Address Prefix as the NLRI of a route. This route shall include a security path attribute with the Air/Ground Subnetwork Type and ATC Class security tags (if any) determined from locally known information.

Note 1. This provides routing information for destinations in the Air/Ground Router's RD and assumes that the eleven octet prefix of the Air/Ground Router's NET is common to all destinations in that RD.

- b) The IS-SME shall insert into the loc-RIB, other routes available through the Air/Ground Router and determined using locally known information, indexed by the received NET. This route shall include a security path

attribute with the Air/Ground Subnetwork Type and ATC Class security tags (if any) determined from locally known information.

Note 2. As these routes are not subject to dynamic update, their availability must be guaranteed by the operator of the Air/Ground Router, within the limits specified for the applications that will use them.

A6.5.2.11 Air-Ground Route Termination

Note 1. The "Leave Event" is defined to signal when subnetwork connectivity with a remote ATN Router over a mobile subnetwork ceases to be available. This event may be generated by (a) the subnetwork itself using mechanisms outside of the scope of this specified, or (b) the SNDCF when it receives a clear indication from the subnetwork reporting either a network or a user initiated call clearing. The Leave Event is always reported to the IS-SME.

Note 2. When a Leave Event is generated by a subnetwork, it applies to all subnetwork connections to a given DTE. When it is generated locally by the SNDCF, it typically applies to a single subnetwork connection.

When a mobilethe subnetwork does not provide a network generated clear indication (e.g. to indicate that an aircraft has left the range of the mobile subnetwork, or when some other communication failure occurs, etc.), an ATN Routerthe responding BIS shall maintain a "watchdog" timer for each affected subnetwork connectionvirtual circuit and clear each such subnetwork connectionvirtual circuit once activity has ceased for a configurable period (1 - 600 seconds) and dependent upon the subnetwork itself. When such a "watchdog" timer expires, this shall be reported as a "Leave Event" for that subnetwork connection.

Note 3.— An ATN RouterThe responding BIS maintains a "watch-dog" timer for each applicable subnetwork connectionvirtual circuit to detect the event of an aircraft leaving coverage (or other communication failure), if such an event detection is not provided by the subnetwork. This "watch-dog" timer is configurable from 1 to 600 seconds.

When an IS-SME receives a Leave Event for a subnetwork connection or a DTE on a subnetwork, then it shall ensure that respectively, either the affected subnetwork connection or all subnetwork connections on that subnetwork and with the identified DTE, are cleared.

When local Systems Management receives a notification reporting loss of the subnetwork connection, If, as a result of this procedure, there are no other alternative subnetwork connections with the ATN Router that initiating was the ultimate subject of the Leave Event BIS associated with that subnetwork connection, then, except for the case of an Airborne Router implementing the procedures for the optional non-use of IDRP, an IDRP deactivate action "stop event" shall be invoked to terminate the BIS-BIS connection with that ATN Router initiating BIS.

Note 4. As a consequence of the deactivate action and following normal IDRP operation, the IDRP Routing Decision process will be invoked, the local FIB updated and routes previously available via the remote ATN Router may be withdrawn if suitable alternatives are not available.

In the case of an Airborne Router implementing the procedures for the optional non-use of IDRP, the receipt of a Leave Event by the IS-SME shall result in the removal from the loc-RIB of all routes that had been inserted into it as a result of an ISH PDU having been received from the Air/Ground Router for which the Leave Event reports a loss of connectivity.

If the BIS-BIS connection is not re-established within a period configurable from 1 minute to 300 minutes, or when the resources are required for other use, then the adjacent BIS Managed Object associated with the initiating BIS shall be deleted, and the initiating BIS's NET removed from the external BIS Neighbor attribute of the BIS's idrpConfig Managed Object.

A6.6 Handling Routing Information

All ATN Routers BISs in the same RD shall implement the same routing policy.

Note 1. As specified in appendix 11, an ATN Router supports both the empty (default) RIB_Att, and the RIB_Att comprising the Security Path Attribute identifying the ATN Security Registration Identifier, only. An ATN Router therefore includes two RIBs known as the default RIB and the Security RIB, each of which comprises a loc-RIB, and an Adj-RIB-in and an Adj-RIB-out for each adjacent BIS.

Note 2.— Each ATN RD will necessarily have a distinct routing policy that depends on its nature,

and the nature of the RDs to which it is interconnected. This section clause specifies the baseline Routing Policy for each class of RD identified in AA6.3.1 Clause 6.2. ATN RDs may then extend the specified baseline to match their actual requirements.

Note 3.— Each Routing Policy is expressed as a set of policy statements or rules.

Note 4.— These baseline policy statements given below are always subject to the ISO/IEC 10747 requirement that routes are only advertised when the DIST_LIST_INCL and DIST_LIST_EXCL path attributes, if present, permit the route to be so advertised. Routes may never be advertised to an RD or RDC which the route has already traversed.

A6.6.1 Route Origination

An ATN Router shall originate routes to local destinations, as specified by a System Administrator under both the empty (default) RIB_Att and the RIB_Att identified by the Security Path Attribute and ATN Security Registration Identifier. In the latter case, the security path attribute shall contain an empty security information field.

Note. A locally originated route is only advertised to an adjacent ATN Router if a local policy rule exists to permit this to occur (see AA6.6.4.2.5). Such policy rules may also cause information to be placed in the security information field of the security path attribute.

A6.6.2 Receiving Overlapping Routes

When an ATN Router receives a route from an adjacent BIS that is either more specific or less specific than a route already contained in the associated Adj-RIB-in, then it shall install the newly received route in the Adj-RIB-in, without affecting the existing route.

Note. this is option (a) of ISO 10747 clause 7.16.3.1.

A6.6.3 Route Selection

Note 1. ISO/IEC 10747 clause 7.16.2 permits a loc-RIB that is identified by a RIB_ATT containing the Security Path Attribute, to contain more than one route to the same NLRI, provided that those routes provide the same level of protection.

When the Security Registration Identifier in an IDRP Security Path Attribute indicates the ATN Security Policy, then all routes shall be assumed to offer the same level of protection.

Note 2. the purpose of this statement is to permit, within the limitations imposed by IDRP, the existence in the loc-RIB of multiple routes to the same aircraft which differ only in the security related information.

During the Phase 2 Routing Decision process, when two or more routes to the same or overlapping destinations of equal and the highest local preference, are found in adj-RIB-ins identified by a RIB_Attr that includes the Security Path Attribute, but which differ in the security information contained in their security path attribute, then all such routes shall be selected and copied to the corresponding loc_RIB. Otherwise, a local routing policy rule shall be applied to select one and only one of those routes, which shall be copied to the corresponding loc_RIB.

If required by its own Routing Policy, an ATN RD shall, as part of its routing decision process and with reference to the route's RD_PATH, shall not select a route that has passed through an RD or RDC that is unacceptable to the ATN RD for relaying data associated with the traffic type information contain in the route's security typepath attribute security information field.

A6.6.4 Generation of the Forwarding Information Base

A6.6.4.1 Implementation Model

An ATN Router shall support multiple Forwarding Information Bases (FIBs), each identified by a different combination of the following CLNP Header parameters:

- a) QoS Maintenance Parameter value (with the Congestion experienced bit masked to zero)
- b) Security Parameter value (Globally Unique format only),

including the absence of either or both of these parameters in the CLNP Header.

Note 1. The above requirements describe an abstract implementation model and provide an implementation context for other requirements. They are not intended to prescribe an actual implementation model. The implementation implied

by the above is not mandatory and any implementation which gives identical externally visible behaviour is in compliance with this specification.

Note 2. The actual number of FIBs that any given ATN Router supports is dependent on the type of application data that it will route, which is itself dependent on the routing policy implemented by the Router. An upper bound may be derived from the number of combinations of security parameter values and QoS Maintenance Parameter values permitted in appendix 9.

Note 3. For CNS/ATM-1 Package the QoS Maintenance parameter is not expected to be used in the CLNP forwarding decision. Any use of this parameter for CLNP forwarding is a local matter.

When forwarding a CLNP NPDU and a FIB cannot be found that is identified by the combination of the QoS Maintenance and Security Parameter values contained in the NPDU's header, then the absence of the QoS Maintenance parameter shall be assumed. If a FIB cannot then be identified (i.e. identified by the combination: no QoS Maintenance parameter, value of Security Parameter), then the NPDU shall be discarded and an error report PDU returned if requested by the originator.

Note 3. The above requirement ensures that for CNS/ATM-1 Package, any value of the QoS Maintenance parameter may be given without affecting the forwarding procedure unless a local decision has been made to act upon this parameter value.

A6.6.4.2 FIB Update

In support of inter-domain routing, an ATN Router shall derive all entries in its FIBs from the loc-RIB(s) maintained by IDRP.

Note 1. In support of intra-domain routing, the FIB information is derived from intra-domain routing information. This is outside the scope of this specification.

Note 2. The relationship between a loc_RIB(s) and the FIBs, is a many to many relationship where many different FIBs may depend on the same loc_RIB, and with more than one loc-RIB being able to provide routes used in the construction of a FIB, and according to local policy rules.

An ATN Router shall maintain a set of Routing Policy rules that determine which routes are

selected from the loc_RIB(s) in order to build each FIB.

Note 3. The actual number of FIBs that an ATN Router supports is dependent on local policy and the types of traffic that it may route. For example, an ATN Router that supports all types of traffic recognised by this specification will support a total of 22 FIBs.

A6.6.4.2.1 Generating the Default FIB

The FIB identified by the absence of the CLNP Header QoS Maintenance and Security Parameters shall be built from routes contained in:

- a) The Default loc-RIB, and
- b) Routes contained in the the Security Loc-RIB which have either no Air/Ground Subnetwork Security Tag, or an Air/Ground Subnetwork Security Tag with a value that indicates that General Communications Traffic is permitted.

A FIB entry shall be generated for each distinct NSAP Address Prefix contained in the NLRI of these routes, except for overlapping routes which shall be processed according to AA6.6.4.2.3. When a given NSAP Address Prefix is included in the NLRI of more than one route, then the preferred route shall be selected according to a locally defined rule.

A6.6.4.2.2 Generating FIBs Identified by the CLNP Security Parameter and no QoS requirement

Table AA6-2 shall identify the loc_RIB(s) to be used as the source for the FIBs identified by;

- a) either the absence of the QoS Maintenance Parameter in the CLNP Header or a value indicating no QoS preference, and
- b) when the security parameter is present in the CLNP Header and when no security classification security tag is contained in the security parameter.

Note 4. The value of the security tag “Traffic Type and Associated Routing Policies” is therefore used to identify each FIB.

For each so identified FIB, a FIB entry shall be generated for each distinct NSAP Address Prefix contained in the NLRI of the routes contain in the loc-RIB(s) identified by Table AA6-2 as the source loc-RIB. When the Security Loc-RIB is used as the

source, then the routes shall be filtered to exclude those routes that do not satisfy the additional requirements given in Table AA6-2:

- a) If a Security Tag filter is identified in Table AA6-2 for the Air/Ground Subnetwork Type security tag, then a route shall be selected if and only if the Air/Ground Subnetwork Type is either absent or the identified traffic type is permitted to travel over the route.
- b) If a Security Tag filter is identified in Table AA6-2 for the ATC Class security tag, then a route shall be selected if and only if the ATC Class security tag is present in the route and the ATC Class it identifies is equal to or better than the class identified in Table AA6-2.
- c) If a subnetwork requirement is identified in Table AA6-2, then a route shall be selected if and only if the Air/Ground Subnetwork Type security tag is present in the route and identifies the route as passing over at least one of the mobile subnetwork types for which a column entry is present in Table AA6-2.

When a given NSAP Address Prefix is included in the NLRI of more than one route, then the preferred route shall be selected according to AA6.6.4.2.4. Overlapping routes shall be processed according to AA6.6.4.2.3.

Note 5. Generation of FIBs in support of classified data is outside of the scope of this specification.

A6.6.4.2.3 Overlapping Routes

In the case of overlapping routes, either both routes shall be selected or the less specific route only. Both are selected when the more specific route provides the preferred path for its destinations, according to the tie breaking rules given below in AA6.6.4.2.4. The less specific only shall be selected when it always provides the preferred path, even for those destinations in common with the more specific route.

A6.6.4.2.4 Tie Breaking

When a given NSAP Address Prefix is included in the NLRI of more than one route not excluded by the application of the above rules, then the preferred route shall be selected as follows:

- a) If the route contains an Air/Ground Subnetwork Type Security Tag set and the rules for generating the FIB given in Table AA6-2 include a Subnetwork Requirement,

then the route that is identified by its Air/Ground Subnetwork Type Security Tag set as having passed over the mobile subnetwork corresponding to the lowest numerical entry in the Table AA6-2 Subnetwork Requirements, shall be preferred.

- b) If the route contains an ATC Class Security Tag and the rules for generating the FIB given in Table AA6-2 include a filter on the ATC Class Security Tag, then the route with the lowest value of the ATC Class Security Tag set shall be preferred.
- c) Otherwise, a local rule shall be used to determine the preferred route.

CLNP FIB Selection Criteria				Source loc-RIB		Security Tag Filters		Subnetwork Requirements				
Traffic Type	Category	Security Tag Value	Semantics	Default Loc-RIB	Security Loc-RIB	Air/Ground Subnetwork Type security tag	ATC Class security tag	Mode S	AMSS	VDL	Gate-link	HF
ATN Operational Communications	Air Traffic Service Communications (ATSC)	000 00001	No Traffic Type Policy Preference		✓	ATC Permitted ¹	²					
		000 10000	Traffic only follows Class A ATSC route(s).		✓	ATC Permitted	At least Class A ³					
		000 10001	Traffic only follows Class B ATSC route(s).		✓	ATC Permitted	At least Class B					
		000 10010	Traffic only follows Class C ATSC route(s).		✓	ATC Permitted	At least Class C					
		000 10011	Traffic only follows Class D ATSC route(s).		✓	ATC Permitted	At least Class D					
		000 10100	Traffic only follows Class E ATSC route(s).		✓	ATC Permitted	At least Class E					
		000 10101	Traffic only follows Class F ATSC route(s).		✓	ATC Permitted	At least Class F					
		000 10110	Traffic only follows Class G ATSC route(s).		✓	ATC Permitted	At least Class G					
		000 10111	Traffic only follows Class H ATSC route(s).		✓	ATC Permitted	At least Class H					
		000 00011	Route Traffic using an ordered preference of Mode S first, then VHF Data Link, then Satellite Data Link, then HF Data Link.		✓	ATC Permitted		1	3	2	5	4
	Aeronautical Operational Control (AOC)	001 00001	No Traffic Type Policy Preference.		✓	AOC Permitted						
		001 00010	Route Traffic only via Gatelink.		✓	AOC Permitted					1	
		001 00011	Route Traffic only via VHF Data Link.		✓	AOC Permitted			1			

¹ The filter shall ensure that if the Air/Ground subnetwork type security tag is present then, the ATC permitted bit in the second octet is set

² Absence of a filter requirement shall imply that any value including the absence of the path attribute, is acceptable.

³ The semantic of "at least class n" shall be that an ATC Class security tag must be present and the class shall be at a minimum class n.

CLNP FIB Selection Criteria				Source loc-RIB		Security Tag Filters		Subnetwork Requirements				
Traffic Type	Category	Security Tag Value	Semantics	Default Loc-RIB	Security Loc-RIB	Air/Ground Subnetwork Type security tag	ATC Class security tag	Mode S	AMSS	VDL	Gate-link	HF
		001 00100	Route Traffic only via Satellite Data Link.		✓	AOC Permitted			1			
		001 00101	Route Traffic only via HF Data Link.		✓	AOC Permitted						1
		001 00110	Route Traffic only via Mode S Data Link.		✓	AOC Permitted		1				
		001 00111	Route Traffic using an ordered preference of Gatelink first, then VHF Data Link.		✓	AOC Permitted				2	1	
		001 01000	Route Traffic using an ordered preference of Gatelink first, then VHF Data Link, then Satellite.		✓	AOC Permitted			3	2	1	
		001 01001	Route Traffic using an ordered preference of Gatelink first, then VHF Data Link, then HF Data Link, then Satellite Data Link.		✓	AOC Permitted			4	2	1	3
ATN Administrative Communications		001 10000			✓	ATN Administrative Permitted						
General Communications		010 00000		✓	✓	General Communications Permitted						
ATN Systems Management Communications		011 00000		✓	✓	ATN Systems Management Permitted						

Table AA6-2 FIB Generation Rules

A6.6.4.2.5 Choice of Subnetwork Path

When more than one subnetwork supports the selected route for a given NSAP Address Prefix (i.e. the adjacency with the next hop BIS), then the FIB shall identify as the next hop subnetwork, for NPDUs for which that NSAP Address Prefix provides the longest match with the NPDU's destination address, the subnetwork that supports the adjacency and satisfies the following:

- a) If the corresponding FIB Generation Rule in Table AA6-2 (if any) includes a Security Tag Filter on the Air/Ground Subnetwork Type Security Tag, and the adjacency is supported by mobile subnetworks, then only a subnetwork which permits the traffic type identified in Table AA6-2, shall be used as the next hop subnetwork.
- b) If the corresponding FIB Generation Rule in Table AA6-2 (if any) includes a Security Tag Filter on the ATC Class, then only a subnetwork which is locally known to support an ATC Class of at least that identified in Table AA6-2, shall be used as the next hop subnetwork.
- c) If the corresponding FIB Generation Rule in Table AA6-2 (if any) includes one or more entries in the subnetwork requirements columns, and the adjacency is supported by mobile subnetworks, then the subnetwork chosen shall be that which is available and which corresponds to the lowest numerical entry in the Table AA6-2 Subnetwork Requirements.
- d) Otherwise, a local routing policy rule shall be used to choose the appropriate subnetwork.

Note. When the next hop is supported by a virtual subnetwork path (e.g. between two ATN Routers in the same RD but not attached to the same subnetwork), then the actual subnetwork path is determined from information provided by the intra-domain routing function. This mechanism is outside of the scope of this specification.

A6.7 Policy Based selection of Routes for Advertisement to Adjacent RDs

Note 1. In general, the selection of routes for advertisement to adjacent Routing Domains is

performed according to local routing policy rules. This specification mandates such routing policy rules for support of air-ground routing only. Routing Policy rules for support of ground-ground routing are a local matter.

Editor's Note. The above statement is not consistent with the recommendations concerning non-ATN RDs. My working assumption is that the above statement is correct and that these recommendations should be in guidance material. Therefore, I have deleted them.

A route shall only be advertised by an ATN RD to an adjacent ATN RD when it can be ensured that data sent over that route by the RD to which the route is advertised, is acceptable to every RD and RDC in the route's path, and will be relayed by them to the route's destination.

Note 2.- The acceptability of a route may be determined using a priori knowledge derived from interconnection agreements with other RDs.

A6.7.1 Routing Policy Requirements for Members of an ATN Island Backbone RDC

An ATN RD that is a member of an ATN Island Backbone RDC shall implement a Routing Policy that is compatible with the policy statements given in this section and its subordinate sections.

Note.— The routing policies expressed in this section do not constrain RD policies as much as define whether an RD's policies define it as being in the backbone or not.

A6.7.1.1 Adjacent ATN RDs within the Backbone RDC

Note 1.— These policy statements apply to the routes advertised by an ATN Router~~BIS~~ in a RD that is a member of a Backbone RDC, to an adjacent ATN Router~~BIS~~ in a different RD, ~~but~~ which is also a member of the same ATN Island Backbone RDC.

Each ATN Router that is in an RD that is a member of When an ATN Island's includes a Backbone RDC, each ATN Backbone RD shall provide the following routes to each adjacent ATN RD within the same Backbone RDC, and for the Security RIB for each RIB-Att in common:

Editor's note. I have deleted the DIST_LIST_INCL requirement below and in all

similar cases and moved it to the subsequent note. This is because it appears to represent over-specification i.e. it is not necessary to work and, as a local matter, RDs may want to widen the distribution scope.

- a) A route to NSAPs and NETs contained within the RD; the route's destination shall be one or more NSAP Address prefixes common to all NSAP Addresses and NETs in the RD. If restrictions on distribution scope are applied by local routing policy, then they shall not prevent distribution of this route to any member of the same ATN Island RDC. The well known discretionary attribute `DIST_LIST_INCL` shall be present, unless the RD permits routes to destinations within itself to be advertised by other ATN RDs to any non-ATN RD. When the attribute is present it shall contain the RDI of the ATN RDC as its value.

Note 2.— The well known discretionary attribute `DIST_LIST_INCL` may also be present. For example, to restrict the scope of the information to members of the ATN Backbone RDC only. The RDIs of other RDs and RDCs may also be present at the discretion of the local Administrative Domain, and by bilateral agreement.

Note 3.— The objective of this rule item is to ensure that a member of a backbone RDC will tell all its neighbours within the backbone about itself.

- b) The selected route to every Mobile RD for which a route is available.

Note 4.— The objective of this rule item is to ensure that a member of a backbone RDC will inform all other backbone RDC members within the island about all routes to all mobiles that it has available.

- c) The selected route to every Fixed ATN RD in the same ATN Island, for which a route is available.

Note 5.— The objective of this rule item is to ensure that a member of a backbone RDC will tell other members of the same backbone RDCs about all fixed RDs that it knows about.

- d) Each selected route to a Mobile RD's "home".

Note 6.— The objective of this rule item is to ensure that a member of a backbone RDC will

tell all fixed RDs about all the "homes" that it knows about.

Note 7.— Such a route can be characterised by an NSAP Address Prefix which ends at the RDF field and the RDF field takes the value 081h.

Recommendation.— An ATN Backbone RD should also provide routes to destinations outside of the ATN Island RDC which have been advertised to it by non-ATN RDs, when those routes are those currently selected by the route selection algorithm.

Note 8.— The objective of this item is to recommend that a backbone RD will tell all other ATN RDs within the backbone that want to know it about its non-ATN connectivity.

A6.7.1.2 All other ATN RDs within the ATN Island

Note 1.— These policy statements apply to the routes advertised by an ATN RouterBIS in an RD that is a member of a Backbone RDC to an adjacent ATN RouterBIS in a different RD, which is also a member of the same ATN Island RDC, but which is not a member of the ATN Island's Backbone RDC.

An ATN Router that is in an RD that is a member of an ATN Island Backbone RDC shall provide the following routes to each adjacent ATN RD within the ATN Island RDC, which are not members of the ATN Island's other than other Backbone RDCs, and for the Security RIB for each RIB-Att in common:

- a) A route to NSAPs and NETs contained within the RD; the route's destination shall be one or more NSAP Address prefixes common to all NSAP Addresses and NETs in the RD. If restrictions on distribution scope are applied by local routing policy, then they shall not prevent distribution of this route to any member of the same ATN Island RDC. The well known discretionary attribute `DIST_LIST_INCL` shall be present, and shall contain the RDI of the ATN Island RDC as its value.

Note 2.— The well known discretionary attribute `DIST_LIST_INCL` may also be present. For example, to restrict the scope of the information to members of the ATN Island only. The RDIs of other RDs and RDCs may also be present at the discretion of the local Administrative Domain, and by bilateral agreement.

Note 3.— The objective of this ruleitem is to ensure that a member of a backbone RDC will tell all RDs within the island about itself.

- b) The selected route to every Fixed ATN RD in the same ATN Island for which a route is available.

Note 4.— The objective of this ruleitem is to ensure that an ATN Router located in an RD that is a member of a backbone RDC, will tell all RDs within the island about all the fixed RDs it knows about.

- c) A route to all AINSC mobiles and all ATSC Mobiles. The well known discretionary attribute DIST LIST INCL shall be present, and shall contain the RDI of the ATN Island RDC as its value.

Note 5. - The objective of this rule is to tell the rest of the Island that each RD in the Backbone RDC provides a default route to all aircraft.

Note 6. The distribution scope of the route is limited because the ATN Island defines the domain of the default route provider. This route is invalid outside of the ATN Island.

Note 7. This route is formally the result of aggregating all the routes to mobile systems and routes to "Home" RDs, known to the ATN Router.

Each selected route to a Mobile RD's "home".

Note 5.— The objective of this item is to ensure that a backbone RD will tell all RDs within the island about all the homes it knows about.

Note 6.— Such a route can be characterized by an NSAP Address Prefix which ends at the RDF field and the RDF field takes the value 081h.

A route to each Mobile RD for which a route is available and which the receiving RD has previously declared an interest.

Note 7.— The objective of this item is to ensure that a backbone RD will tell all the RDs within the island about all mobiles that these RDs want to know about. Airlines are expected to want to know about their aircraft, whereas Administrations may tend to want to know about mobiles within the island.

Note 8.— The mechanism by which an RD identifies the mobiles for which it requires routing information is outside of the scope of this manual. [a6-n-0540]

Note 9.— ATSC RDs will typically wish to receive routing information about all mobiles reachable via other RDs within the same ATN Island. AINSC RDs will typically be interested in routing information for aircraft belonging to the same airline. [a6-n-0550]

Recommendation.— An ATN Backbone RD should also provide routes to destinations outside of the ATN Island RDC which have been advertised to it by non-ATN RDs, when those routes are those currently selected by the route selection algorithm.

Note 10.— The objective of this item is to recommend that a backbone RD will tell all other ATN RDs, that want to know it, about their non-ATN connectivity.

A6.7.1.3 Mobile RDs

Note 1.— These policy statements apply to the routes advertised by an ATN RouterBIS in an RD that is a member of a Backbone RDC to an adjacent ATN RouterBIS in a Mobile RD.

An ATN Routers in an RD that is a member of a Backbone RDC shall provide the following routes to each adjacent Mobile RD, for the Security RIB for each RIB-Att in common:

- a) A route to NSAPs and NETs contained within the RD; the route's destination shall be one or more NSAP Address prefixes common to all NSAP Addresses and NETs in the RD.

Note 2.— The objective of this ruleitem is to ensure that an RD that is a member of a backbone RDC will tell all adjacent mobiles about itself.

- b) An aggregated route to NSAPs and NETs contained within the local ATN Island RDC;

Note 3.— The objective of this ruleitem is to ensure that an RD that is a member of a backbone RDC will be willing to provides to each connected mobile RD, a routing information to all fixed ATN RDs within the island.

- c) An aggregated route to NSAPs and NETs contained within all other ATN Islands for which a route is available.

Note 4.— The objective of this ~~ruleitem~~ is to ensure that an RD that is a member of a backbone RDC will be willing to provide to each connected mobile RD routing information to the backbone of other ATN islands.

A6.7.1.4 ATN RDs in other ATN Islands

Note 1.— These policy statements apply to the routes advertised by an ATN Router BIS in an RD that is a member of a Backbone RDC to an adjacent ATN Router BIS in a different RD, which is a member of a different ATN Island's ATN Island Backbone RDC.

An ATN Router in an RD that is a member of a Backbone RDC shall provide the following routes to each adjacent ATN Router that is a member of a Backbone RDC in another ATN Island, and for the Security RIB for each RIB-Att in common:

- a) An aggregated route to NSAPs and NETs contained within the ATN Island RDC.

Note 2.— The objective of this ~~ruleitem~~ is to ensure that an RD that is a member of a backbone RDC will tell all adjacent RDs that are members of backbone RDCs in different ATN Islands about the local ATN Island.

- b) A route to the common NSAP Address Prefix for each group of Mobile RDs for which the "home" exists on the RD's ATN Island. The well-known discretionary attribute DIST_LIST_INCL shall be present, and shall contain the RDI of the ATN RDC as its value.

Note 3.— The RDIs of other RDs and RDCs may also be present at the discretion of the local Administrative Domain, and by bilateral agreement.

Note 3.— The objective of this ~~ruleitem~~ is to ensure that a backbone RD will tell all adjacent a backbone RD in different islands about routes to mobiles whose home is in that island.

Note 4.— The "home" identified above need not correspond to with a geographical notion of a home.

Note 5.— The "home" is typically identified by an NSAP Address Prefix that identifies all the RD's belonging to the organisation responsible for the Mobile RD (i.e. aircraft), or all the Mobile RDs belonging to the organisation. The

former is only possible if all such Fixed RDs are part of the same ATN Island RDC.

- c) A route to each Mobile RD for which the adjacent Backbone RD is advertising a route to the Mobile RD's "home".

Note 7.— The objective of this ~~ruleitem~~ is to ensure that a member of a backbone RDC will tell all adjacent ~~backbone~~ RDs in different islands about all the "homes" that they know about.

- d) A route to each Mobile RD for which there is no known home.

Note 8.— The objective of this ~~ruleitem~~ is to ensure that an RD that is a member of a backbone RDC will tell all adjacent RDs that are members of backbone RDCs in different ATN Islands about all of the Mobile RDs that they know about.

Recommendation.— An ATN Backbone RD should also provide routes to destinations outside of the ATN Island RDC which have been advertised to it by non-ATN RDs, when those routes are those currently selected by the route-selection algorithm.

Note 9.— The objective of this item is to recommend that a backbone RD will tell adjacent backbone RDs in different islands that want to know it about their non-ATN connectivity.

Adjacent Non-ATN RDs

Note 1.— These policy statements apply to the routes advertised by a BIS in a Backbone RD to an adjacent BIS in a non-ATN RD.

Recommendation.— An ATN Backbone RD with adjacent non-ATN RDs, should provide to each adjacent non-ATN RD, a route to NSAPs and NETs contained within the RD, for each RIB-Att in common; the route's destination should be one or more NSAP Address prefixes common to all NSAP Addresses and NETs in the RD [a6 r 0080]. DIST_LIST_INCL or DIST_LIST_EXCL path attributes should be present at the discretion on the Network Administrator of the advertising ATN Backbone RD.

Note 2.— The objective of this item is to recommend that all ATN RDs will tell all adjacent non-ATN RDs about itself.

Recommendation.— An ATN Backbone RD with adjacent non-ATN RDs should provide to each

adjacent non-ATN RD, routes to destinations within the ATN and advertised by adjacent ATN RDs when those routes are those currently selected by the route selection algorithm, and are for a RIB-Att in common.

Note 3.— The objective of this item is to recommend that all ATN RDs will tell all adjacent non-ATN RDs about any connectivity within ATN allowed.

A6.7.2 Routing Policy Requirements for a Mobile RD

A Mobile RD shall provide to each ATN RD to which it is currently connected, a route to NSAPs and NETs contained within the Mobile RD for the Security RIB for each RIB-Att in common.

Note 1.— The objective of this rule item is to ensure that a mobile RD will tell adjacent RDs about advertise itself to adjacent RDs.

Note 2.— This policy statement applies to the routes advertised by an ATN RouterBIS in a Mobile RD to an adjacent ATN Air/Ground RouterBIS in an Fixed ATN RD.

A6.7.3 Routing Policy Requirements for an ATN TRD that is not a Member of the ATN Island Backbone RDC

An RD that is a member of an ATN Island RDC, and is a TRD, but which is not a member of that ATN Island's Backbone RDC shall implement a Routing Policy that is compatible with the policy statements given in this section and its subordinate sections.

Note. An ATN RD that operates as a transit routing domain is referred to in this section as an ATN TRD.

A6.7.3.1 Adjacent ATN RDs that are Members of the ATN Island's Backbone RDC

Note 1.— These policy statements apply to the routes advertised by an ATN RouterBIS in an ATN TRD to an adjacent ATN RouterBIS in an RD which is a member of the local ATN Island's Backbone RDC.

When an ATN TRD that is not itself a member of a Backbone RDC is adjacent to an RD that is a member of an ATN Backbone RDC, then it shall provide the following routes to each such adjacent

ATN Backbone RD, and for the Security RIB for each RIB-Att in common:

- a) A route to NSAPs and NETs contained within the RD; the route's destination shall be one or more NSAP Address prefixes common to all NSAP Addresses and NETs in the RD. The well known discretionary attribute DIST_LIST_INCL shall be present unless the RD permits routes to destinations within itself to be advertised by other ATN RDs to any non-ATN RD, and shall contain the RDI of the ATN RDC as its value.

Note 2.— The well known discretionary attribute DIST_LIST_INCL may also be present. For example, to restrict the scope of the information to members of the ATN Island only. The RDIs of other RDs and RDCs may also be present at the discretion of the local Administrative Domain, and by bilateral agreement.

Note 3.— The objective of this rule item is to ensure that a non-backbone-ATN TRD that is not itself a member of the Backbone RDC, will tell all adjacent ATN backbone RDs which are members of the Backbone RDC about itself.

- b) The selected route to every Mobile RD for which a route is available.

Note 4.— The objective of this rule item is to ensure that a non-backbone-ATN TRD that is not itself a member of the Backbone RDC, will tell all adjacent ATN backbone RDs which are members of the Backbone RDC about all mobiles it knows about.

- c) The selected route to every Fixed ATN RD in the ATN Island for which a route is available.

Note 5.— The objective of this rule item is to ensure that a non-backbone-ATN TRD that is not itself a member of the Backbone RDC, will tell all adjacent ATN backbone RDs which are members of the Backbone RDC about all fixed RDs it knows about in the same ATN Island.

Recommendation.— An ATN RD should also provide routes to destinations outside of the ATN Island RDC which have been advertised to it by non-ATN RDs, when those routes are those currently selected by the route selection algorithm.

A6.7.3.2 Adjacent ATN RDs within the same ATN Island and which are not Members of the ATN Island's Backbone RDC

Note 1.— These policy statements apply to the routes advertised by an ATN RouterBIS in an ATN TRD to an adjacent ATN RouterBIS in an ATN RD on the same ATN Island.

An ATN TRD shall provide the following routes to each adjacent ATN RD within the ATN Island RDC, other than other ATNBackbone RDs which are members of the Backbone RDC, and for the Security RIB for each RIB-Att in common

- a) A route to NSAPs and NETs contained within the RD for the Security RIB for each RIB-Att supported; the route's destination shall be one or more NSAP Address prefixes common to all NSAP Addresses and NETs in the RD. The well known discretionary attribute DIST_LIST_INCL shall be present, and shall contain the RDI of the adjacent ATN RD as its value.

Note 2.— The well known discretionary attribute DIST_LIST_INCL may also be present. For example, to restrict the scope of the information to members of the ATN Island only. The RDIs of other RDs and RDCs may also be present at the discretion of the local Administrative Domain, and by bilateral agreement, including the RDI of the Backbone RD or RDC, when the adjacent RD is providing the local RD's route to the Backbone.

Note 3.— The objective of this ruleitem is to ensure that an non-backbone-ATN TRD that is not itself a member of the Backbone RDC, will tell all adjacent RDs within the island about itself.

- b) The selected route to every Fixed RD in the same ATN Island for which a route is available.

Note 3.— The objective of this ruleitem is to ensure that an non-backbone-ATN TRD that is not itself a member of the Backbone RDC, will tell all adjacent RDs within the island about all fixed ATN RDs in the same ATN Island that it knows about.

- c) If the RD is currently advertising the preferred route to all AINSC and ATSC Mobiles, then every route to an AINSC Mobile and an ATSC Mobile that is known to the local RD shall be

advertised to this RD, subject only to constraints imposed by any DIST_LIST_INCL and DIST_LIST_EXCL path attributes.

Note 4.- The objective of this rule is to ensure that the provider of the default route to all aircraft (i.e. the Backbone) is kept informed of the actual location of every aircraft adjacent to the Island.

The selected route to every Mobile RD for which a route is available and in which the receiving RD has previously indicated an interest. The DIST_LIST_INCL attribute shall be present and shall contain no more than the RDI of the adjacent RD, the RDI of the local ATN Island's Backbone RDC, and the RDI of any RDs which provide a route between the adjacent RD and the ATN Island's Backbone.

Note 4. The objective of this item is to ensure that a non-backbone ATN TRD will tell all adjacent RDs within the island about mobiles within the island that they are interested in, but not about mobiles received from the backbone.

Note 5. The mechanism by which an RD identifies the mobiles for which it requires routing information is outside of the scope of this manual.

Each selected route to a Mobile RD's "home"

Recommendation.— An ATN RD should also provide routes to destinations outside of the ATN Island RDC which have been advertised to it by non-ATN RDs, when those routes are those currently selected by the route selection algorithm.

A6.7.3.3 Mobile RDs

Note 1.— These policy statements apply to the routes advertised by an ATN RouterBIS in an ATN TRD to an adjacent ATN RouterBIS in a Mobile RD.

An ATN TRD shall provide to each adjacent Mobile RD a route to NSAPs and NETs contained within the RD for the Security RIB for each RIB-Att in common; the route's destination shall be one or more NSAP Address prefixes common to all NSAP Addresses and NETs in the RD.

Note 2.— The objective of this ruleitem is to ensure that an ATN TRD will tell adjacent mobile RDs about itself.

Recommendation.— An ATN TRD should also provide to each adjacent Mobile RD, and for the

~~Security RIB for each RIB-Att in common~~ and for which a suitable route exists:

- a) an aggregated route to NSAPs and NETs contained within the local ATN Island RDC;
- b) an aggregated route to NSAPs and NETs contained within all other ATN Islands for which a route is available.

Note 3.— The objective of this rule item is to encourage an RD to provide to each adjacent mobile RD routing information to: a) all fixed RDs within the island, and b) other ATN islands.

Adjacent Non-ATN RDs

Note 1.— These policy statements apply to the routes advertised by a BIS in an ATN TRD to an adjacent BIS in a non-ATN RD.

Recommendation.— An ATN TRD with adjacent non-ATN RDs, should provide to each adjacent non-ATN RD, a route to NSAPs and NETs contained within the RD, for each RIB-Att in common; the route's destination should be one or more NSAP Address prefixes common to all NSAP Addresses and NETs in the RD. [a6 r 0140] ~~DIST_LIST_INCL and DIST_LIST_EXCL path attributes should be present at the discretion on the Network Administrator.~~

Note 2.— The objective of this recommendation is to encourage an ATN TRD with adjacent non-ATN RDs to tell them about itself.

Recommendation.— When an ATN TRD has adjacent non-ATN RDs, the RD should provide to each adjacent non-ATN RD, and for each RIB-Att in common, routes to destinations within the ATN advertised by adjacent ATN RDs when those routes are those currently selected by the route selection algorithm.

Note 3.— The objective of this recommendation is to encourage an ATN TRD with adjacent non-ATN RDs to tell them about any connectivity within the ATN allowed.

A6.7.4 The Routing Policy for a Fixed ATN ERD

A Fixed ATN ERD shall provide to each ATN RD to which it is currently connected, a route to NSAPs and NETs contained within the RD, for the Security RIB for each RIB-Att in common.

Note 1. The well known discretionary attribute DIST_LIST_INCL ~~may~~ shall be present, unless the RD permits routes to destinations within itself to be advertised by other ATN RDs without restriction to any other ATN RD, or non-ATN RD. If present, it shall contain as its value the RDI of the ATN RDC.

Note 1.— The RDIs of other RDs and RDCs may also be present at the discretion of the local Administrative Domain, and by bilateral agreement.

Note 2.— These policy statements apply to the routes advertised by an ATN Router ~~BIS~~ in a fixed ATN ERD to an adjacent ATN Router ~~BIS~~ in an ATN RD.

Note 3.— An ERD does not advertise routes to destinations in any other RD, to another RD.

A6.7.5 Route Aggregation and Route Information Reduction

Note. Route Aggregation and Route Information Reduction are performed according to local routing policy rules. Routing Policy rules can be defined that select routes for aggregation and which determine when certain combinations of NSAP Address Prefixes may be subject to route information reduction.

An Air/Ground Router shall aggregate all routes to destinations in Routing Domains in its own ATN Island, other than those to destinations in its own Routing Domain, and similarly perform route information reduction as permitted by the ATN Addressing Plan, before advertising such routes to an airborne Routing Domain.

An Air/Ground Router shall aggregate all routes to destinations in ATN Islands, other than its own ATN Island, and similarly perform route information reduction as permitted by the ATN Addressing Plan, before advertising such routes to an airborne Routing Domain.

A6.8 Use of the Forwarding Information Base

The forwarding processes for a CLNP NDPDU shall operate by selecting the FIB identified by the combination of the QoS Maintenance and Security Parameters found in the CLNP Header, and selecting from that FIB, the entry, if any, identified by the longest matching NSAP Address Prefix. The

next hop information found in this FIB entry is then used to forward the NPDU.

Two routes shall only be aggregated when their SECURITY attributes, if present, identify the same Security Policy. When two routes are aggregated, if a security classification is present in either of the component routes, then the classification of the aggregated route shall be set to the lower of the two classifications.

Appendix 6 ATN Routing	6-1
A6.1 Introduction	6-1
A6.1.1 Scope	6-1
A6.1.2 References	6-1
A6.1.3 Applicability of Requirements	6-1
A6.2 ATN Routers	6-2
A6.3 The Deployment of ATN Components	6-2
A6.3.1 Routing Domains	6-2
A6.3.2 ATN RDs	6-3
A6.3.2.1 Administration RDs	6-3
A6.3.2.2 Aeronautical Industry RDs	6-3
A6.3.2.3 Mobile RDs	6-3
A6.3.3 Routing Domain Confederations (RDCs)	6-3
A6.3.3.1 Fixed ATN RDC	6-4
A6.3.3.2 ATN Island RDCs	6-4
A6.3.3.3 ATN Island Backbone RDCs	6-5
A6.3.3.4 Other ATN RDCs	6-5
A6.3.4 Administrative Domains and the ATN	6-5
A6.3.5 Interconnection Scenarios	6-5
A6.3.5.1 Interconnection between Members of an ATN Island Backbone RDC	6-5
A6.3.5.2 Interconnection of Between Members of an ATN Island Backbone RDC and other ATN RDs within the ATN Island	6-6
A6.3.5.3 Interconnection of ATN Islands	6-6
A6.3.5.4 Interconnection of Mobile and Fixed RDs	6-6
A6.3.5.5 Interconnection of ATN RDs and non-ATN RDs	6-6
A6.4 Ground-Ground Interconnection	6-6
A6.4.1 Interconnection Scenarios	6-6
A6.4.2 Ground-Ground Route Initiation	6-6
A6.4.3 Ground-Ground Routing Information Exchange	6-7
A6.4.4 Ground-Ground Route Termination	6-7
A6.5 Air-Ground Interconnection	6-8
A6.5.1 Interconnection Scenarios	6-8
A6.5.2 Air-Ground Route Initiation	6-8
A6.5.2.1 Route Initiation Procedures for a Responding ATN Router	6-9
A6.5.2.1.1 Emergency Use of a Mobile Subnetwork	6-10
A6.5.2.2 Air-Initiated Route Initiation	6-10
A6.5.2.2.1 Airborne Router Procedures for use of an ISO 8208 Mobile Subnetwork that does not Provide Information on Subnetwork Connectivity	6-10
A6.5.2.2.2 Airborne Router Procedures for use of an ISO 8208 Mobile Subnetwork that does Provide Connectivity Information	6-11
A6.5.2.3 Ground-Initiated Route Initiation	6-11
A6.5.2.4 Exchange of Configuration Information using the ISO 9542 ISH PDU	6-11
A6.5.2.5 Validation fo the Received NET	6-12
A6.5.2.6 Determination of The Routing Information Exchange Procedure by an Air/Ground Router	6-12
A6.5.2.7 Determination of The Routing Information Exchange Procedure by an Airborne Router	6-12
A6.5.2.8 Establishment of a BIS-BIS Connection	6-12
A6.5.2.9 Exchange of Routing Information using IDRP	6-13
A6.5.2.10 Procedures for the Optional non-use of IDRP over an air-ground data link	6-13
A6.5.2.10.1 Air/Ground Router	6-13
A6.5.2.10.2 Airborne Router	6-14
A6.5.2.11 Air-Ground Route Termination	6-14
A6.6 Handling Routing Information	6-15
A6.6.1 Route Origination	6-15

A6.6.2 Receiving Overlapping Routes _____	6-15
A6.6.3 Route Selection _____	6-15
A6.6.4 Generation of the Forwarding Information Base _____	6-16
A6.6.4.1 Implementation Model _____	6-16
A6.6.4.2 FIB Update _____	6-16
A6.6.4.2.1 Overlapping Routes _____	6-17
A6.6.4.2.2 Tie Breaking _____	6-17
A6.6.4.2.3 Choice of Subnetwork Path _____	6-21
A6.7 Policy Based selection of Routes for Advertisement to Adjacent RDs _____	6-21
A6.7.1 Routing Policy Requirements for Members of an ATN Island Backbone RDC _____	6-21
A6.7.1.1 Adjacent ATN RDs within the Backbone RDC _____	6-21
A6.7.1.2 All other ATN RDs within the ATN Island _____	6-22
A6.7.1.3 Mobile RDs _____	6-23
A6.7.1.4 ATN RDs in other ATN Islands _____	6-24
A6.7.2 Routing Policy Requirements for a Mobile RD _____	6-25
A6.7.3 Routing Policy Requirements for an ATN TRD that is not a Member of the ATN Island Backbone RDC _____	6-25
A6.7.3.1 Adjacent ATN RDs that are Members of the ATN Island's Backbone RDC _____	6-25
A6.7.3.2 Adjacent ATN RDs within the same ATN Island and which are not Members of the ATN Island's Backbone RDC _____	6-26
A6.7.3.3 Mobile RDs _____	6-27
A6.7.4 The Routing Policy for a Fixed ATN ERD _____	6-27
A6.7.5 Route Aggregation and Route Information Reduction _____	6-27
A6.8 Use of the Forwarding Information Base _____	6-28